

**BLAUPUNKT**

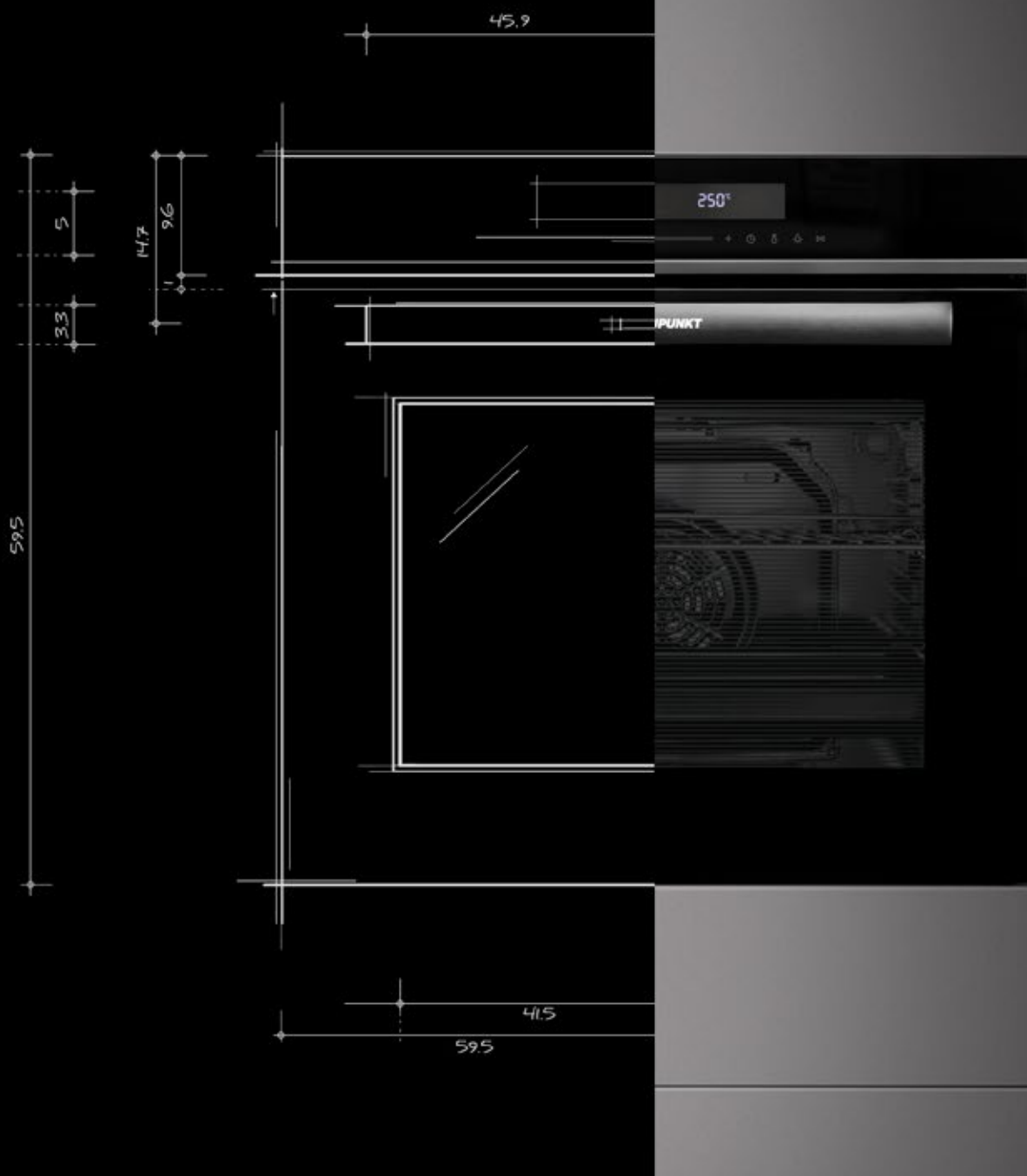

*Enjoy it.*

**nikpol**

Built-in appliances 2022





## Perfectly integrated

Those opting for a modern, state-of-the-art kitchen expect not only appliances that meet the latest technical standards, but also a harmonious overall impression that perfectly combines technology and design. Blaupunkt products offer precisely that.

# Fire

Ovens	10-16
Range cooker	17
Compact appliances	20
Microwaves	21
Warming drawers	23

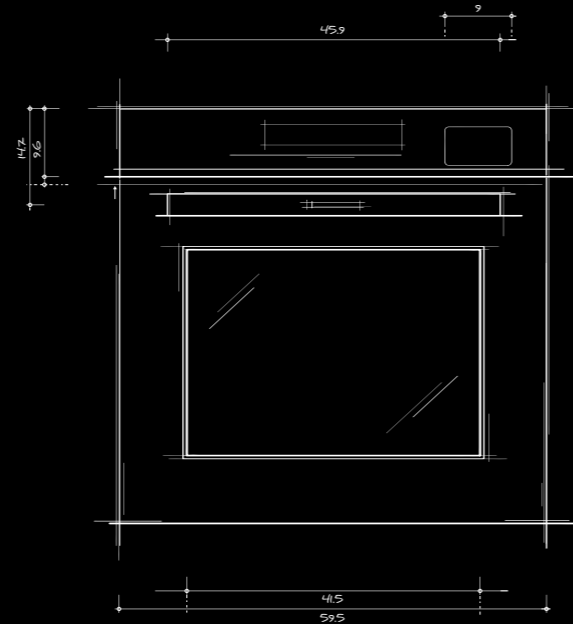

# Air

Ceiling fans	42
Wall hoods	42-43
Flat hoods	44
Fan module	45-47

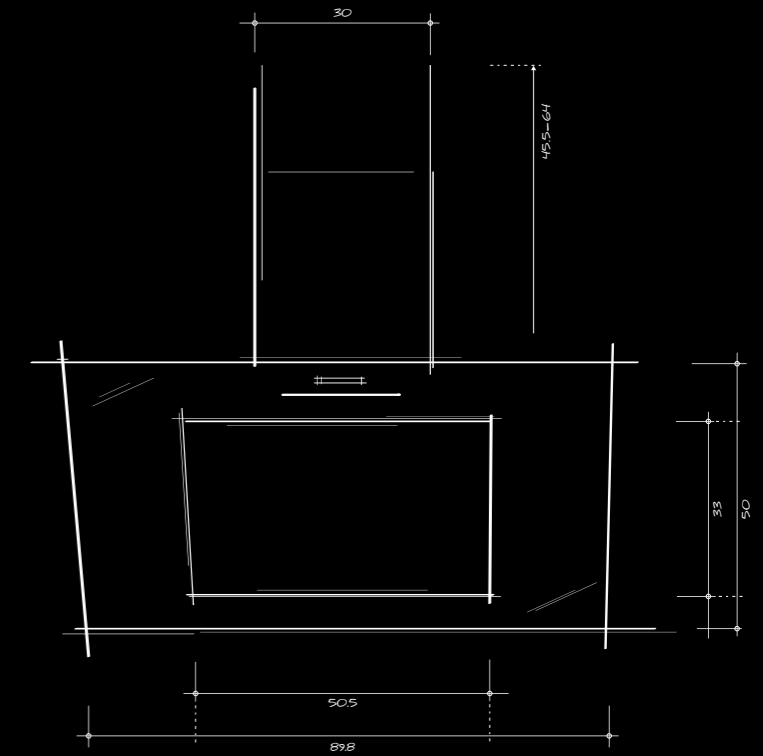

# Heat

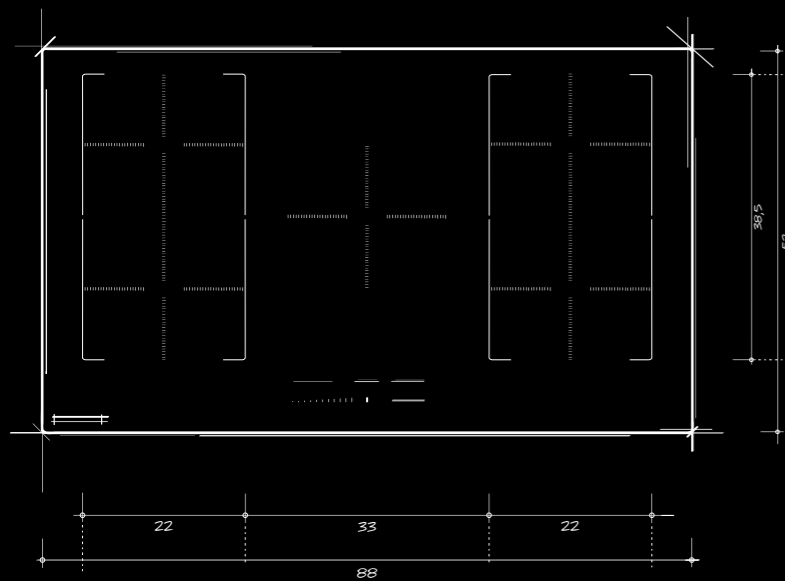

Hobs	26-31
Gas hobs	34-35
Hob with extractor fan	39
Blaupunkt Multi Control	40-41

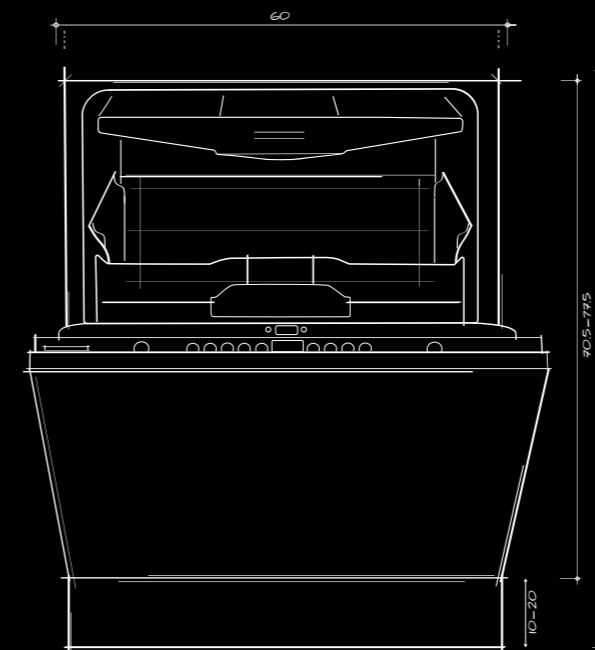

# Water

Dishwasher, 60 cm, partially integrated	50
Dishwasher, 60 cm, fully integrated	50
Dishwasher, 60 cm, free-standing	51

Blaupunkt Additional accessories	54-57
Technical Drawings	60-63



## Blaupunkt ovens – the heart of your kitchen

Crispy, delicate and fresh – all available with a simple touch! Intuitive operating concepts and clearly arranged display solutions allow your oven to produce perfect results. And when the feast is over, these practical kitchen appliances simply clean themselves.



Smart slider

### Smart slider

An intuitive, simple control concept for all appliances – every setting can be perfectly selected with the Smart Slider.



Touch control

### Touch Control

Precise, innovative and very user-friendly: gently touching the Touch Control buttons is enough to select the desired setting.



Automatic programmes

### Automatic programmes

One touch away from the perfect result: our automatic programmes are equipped for nearly every ingredient. Cooking can't get any easier.



Soft moving

### Soft moving

Thanks to its advanced dampers and hinges, the oven door can be opened and closed smoothly. Just a light pull / push and the door opens or closes gently.



Pyrolytic system

### Pyrolysis

With a simple touch, all residues from baking, frying and grilling at high temperatures are reduced to ashes that can be simply wiped away with a cloth.



Hydrolytic system

### Hydrolysis

Easy cleaning at the push of a button: With the aid of heat and steam, even strong stains can be dissolved.



# Fire

# Dark Steel oven series

Aesthetic and modern:  
The new oven series  
from Blaupunkt

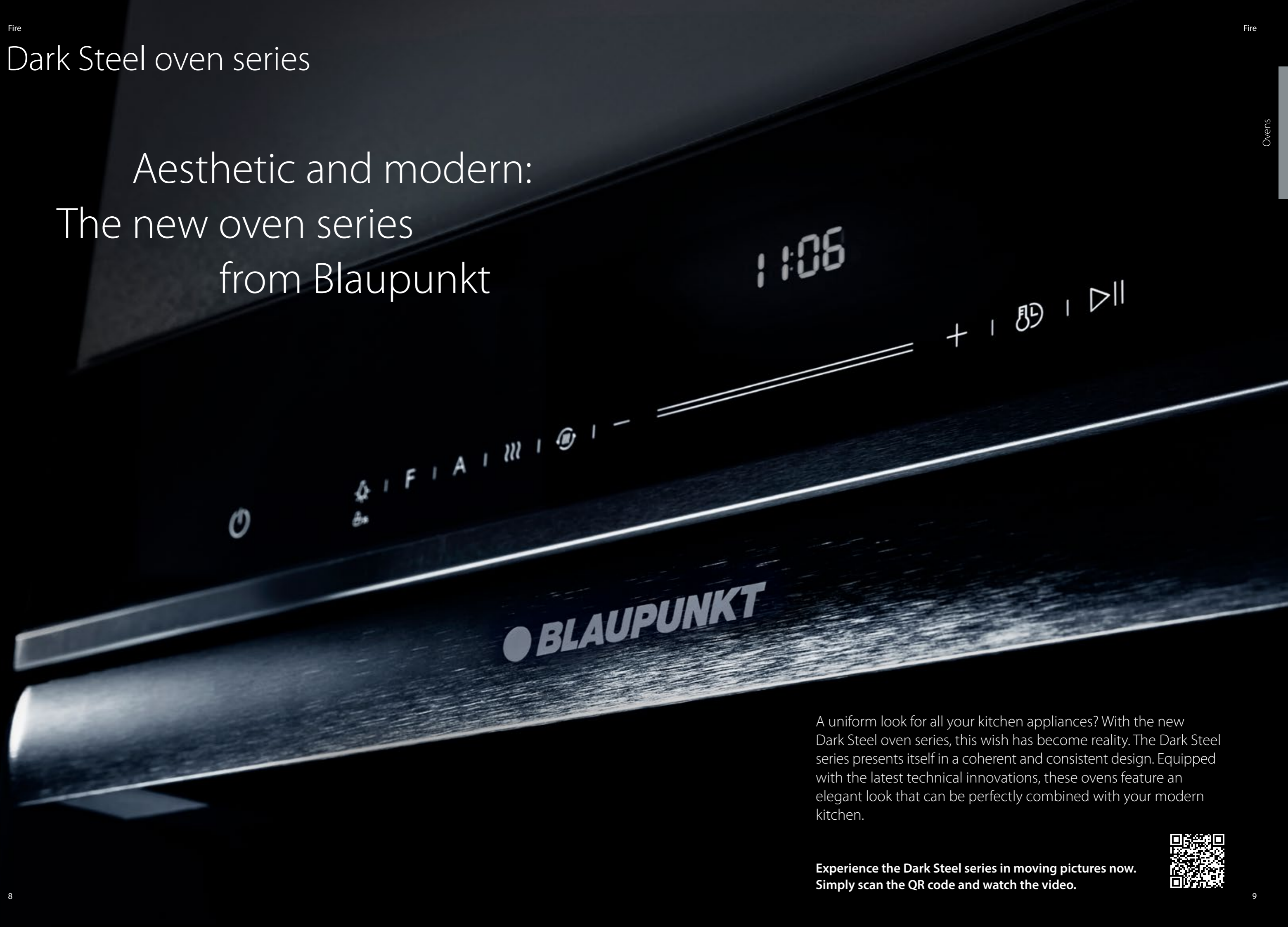

A uniform look for all your kitchen appliances? With the new Dark Steel oven series, this wish has become reality. The Dark Steel series presents itself in a coherent and consistent design. Equipped with the latest technical innovations, these ovens feature an elegant look that can be perfectly combined with your modern kitchen.

Experience the Dark Steel series in moving pictures now. Simply scan the QR code and watch the video.



## Built-in oven

5B50P 8590GB New

**Output, consumption**

- Voltage: 220 – 240 V
- Total connected load: 3.2 kW

**Oven type, heating type**

Built-in electric oven with 11 heating types:

- Top/bottom heat
- Bottom heat
- Hot Air Eco
- Hot air
- Circulation
- Circulation grill
- Vario large area grill
- Vario small area grill
- Pizza level
- Defrost function
- Dough process

**Design, comfort**

- Control panel in the Dark Steel design
- Touch Control
- Smart Slider
- Digital display in white
- Quick heating
- Temperature recommendation
- Electronic temperature regulation from 30°C – 250°C
- Pyrolytic self-cleaning
- Full glass inner door
- Soft-moving door
- Dark Steel metal handle with logo
- Cooking chamber volume 72 l
- Flat oven walls with oven racks
- Enamelled cooking chamber
- Removable oven door for easy cleaning
- Oven lighting
- Safety switch-off
- Child protection, door lock in pyrolysis mode
- Cooling fan
- Large oven interior with 1-way telescopic extension

**Dimensions H x W x D**

- Appliance dimensions: 59.5 x 59.5 x 56.5 cm
- Installation dimensions: 60.0 x 56.0 x 55.0 cm
- Panel height: 96 mm



## Built-in oven

5B50N 8590GB New

**Output, consumption**

- Voltage: 220 – 240 V
- Total connected load: 2.9 kW

**Oven type, heating type**

Built-in electric oven with 11 heating types:

- Top/bottom heat
- Bottom heat
- Hot Air Eco
- Hot air
- Circulation
- Circulation grill
- Vario large area grill
- Vario small area grill
- Pizza level
- Defrost function
- Dough process

**Design, comfort**

- Control panel in the Dark Steel design
- Touch Control
- Smart Slider
- Digital display in white
- Quick heating
- Temperature recommendation
- Electronic temperature regulation from 30°C – 250°C
- Full glass inner door
- Soft-moving door
- Dark Steel metal handle with logo
- Cooking chamber volume 72 l
- Flat oven walls with oven racks
- Enamelled cooking chamber
- Removable oven door for easy cleaning
- Oven lighting
- Safety switch-off
- Child protection, door lock in pyrolysis mode
- Cooling fan
- Large oven interior with 1-way telescopic extension

**Dimensions H x W x D**

- Appliance dimensions: 59.5 x 59.5 x 56.5 cm
- Installation dimensions: 60.0 x 56.0 x 55.0 cm
- Panel height: 96 mm





# Blaupunkt – perfectly planned

Clear design –  
right down the line

Everything in one line, that was our goal when developing the new Blaupunkt Dark Steel series. The appliances are carefully aligned to create you a comfortable kitchen space. Ovens and compact appliances can be combined in various ways – along clear, uniform lines of design with black glass and white displays.

- New look in Dark Steel
- Logo now on the handle
- Black glass for uniform, timeless design
- White display with Smart Slider
- Optimally aligned and ideally combinable

## Built-in oven

## 5B36P 0250AU

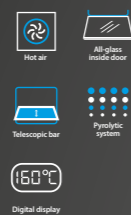
**Output, consumption**

- Voltage: 220–240V
- Total connected load: 3.2 kW

**Oven type, heating type**

Built-in electric oven with 8 heating types:

- Top/bottom heat
- Bottom heat
- Hot Air Eco
- Hot air
- Hot air grill
- Vario large area grill
- Vario small area grill
- Defrost function

**Design, comfort**

- Fully retractable control knob
- Digital display
- Electronic clock
- Quick heating
- Temperature recommendation
- Pyrolytic self-cleaning
- Full glass inner door
- Metal handle
- Cooking chamber volume 70 l
- Flat oven walls with oven racks
- Enamelled cooking chamber
- Removable oven door for easy cleaning
- Oven lighting
- Safety switch-off
- Child protection, door lock in pyrolysis mode
- Cooling fan
- Large oven interior with 1-way telescopic extension

**Dimensions H × W × D**

- Appliance dimensions: 59.5 × 59.5 × 57.5 cm
- Installation dimensions: 59.0 × 56.0 × 55.0 cm
- Panel height: 96 mm



## Built-in oven

## 5B36N 0250AU

**Output, consumption**

- Voltage: 220–240V
- Total connected load: 3.0 kW

**Oven type, heating type**

Built-in electric oven with 8 heating types:

- Top/bottom heat
- Bottom heat
- Hot Air Eco
- Hot air
- Hot air grill
- Vario large area grill
- Vario small area grill
- Defrost function

**Design, comfort**

- Fully retractable control knob
- Digital display
- Electronic clock
- Quick heating
- Temperature recommendation
- Full glass inner door
- Metal handle
- Cooking chamber volume 70 l
- Flat oven walls with oven racks
- Enamelled cooking chamber
- Removable oven door for easy cleaning
- Oven lighting
- Safety switch-off
- Cooling fan
- Large oven interior with 1-way telescopic extension

**Dimensions H × W × D**

- Appliance dimensions: 59.5 × 59.5 × 57.5 cm
- Installation dimensions: 59.0 × 56.0 × 55.0 cm
- Panel height: 96 mm



## Built-in oven

## 5B20N 0290AU

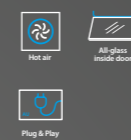
**Output, consumption**

- Voltage: 220–240V
- Total connected load: 2.1 kW

**Oven type, heating type**

Built-in electric oven with 5 heating types:

- Hot Air
- Grill
- Grill with fan
- Defrosting
- ECO

**Design, comfort**

- Temperature regulation from 50 °C–250 °C
- Full glass inner door
- Low window temperature
- Cooking chamber volume 70 l
- Smooth oven walls with suspended grates
- Metal handle
- Enamelled cooking chamber
- Removable oven door for easy cleaning
- Oven lighting
- Cooling fan
- Control lamp for operation condition

**Dimensions H × W × D**

- Appliance dimensions: 59.5 × 59.5 × 57.5 cm
- Installation dimensions: 60.0 × 57.0 × 56.0 cm
- Panel height: 120 mm



## Built-in oven

## 5B10N 0240AU

**Output, consumption**

- Voltage: 220–240V
- Total connected load: 2.1 kW

**Oven type, heating type**

Built-in electric oven with 4 heating types:

- Top heat
- Bottom heat
- Top and bottom heat
- ECO

**Design, comfort**

- Temperature regulation from 50 °C–250 °C
- Full glass inner door
- Low window temperature
- Cooking chamber volume 75 l
- Smooth oven walls with suspended grates
- Metal handle
- Enamelled cooking chamber
- Removable oven door for easy cleaning
- Oven lighting
- Cooling fan
- Control lamp for operation condition

**Dimensions H × W × D**

- Appliance dimensions: 59.5 × 59.5 × 57.5 cm
- Installation dimensions: 60.0 × 57.0 × 56.0 cm
- Panel height: 120 mm





## Built-in oven

## 5BC 94190AU

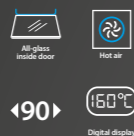
**Output, consumption**

- Voltage: 220 – 240 V
- Total connected load: 2.8 kW

**Oven type, heating type**

Built-in electric oven with 9 heating types:

- Conventional
- Grill
- Double grill
- Double grill with fan
- Bottom heat
- Conventional with fan
- Hot air
- Defrost
- ECO

**Design, comfort**

- Mechanical control
- Fully retractable control knob
- Temperature regulation from 50 °C – 250 °C
- Full glass inner door
- Low window temperature
- Cooking chamber volume 93 l
- Smooth oven walls with suspended grates
- Metal handle
- Enamelled cooking chamber
- Removable oven door for easy cleaning
- Oven lighting
- Cooling fan
- Control lamp for operation condition

**Dimensions H × W × D**

- Appliance dimensions: 90.0 × 54.5 × 48.0 cm
- Installation dimensions: 47.5 – 47.7 × 86.0 × 55.0 – 56.0 cm



## Built-in oven

## 5BC 93190AU

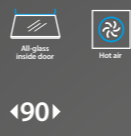
**Output, consumption**

- Voltage: 220 – 240 V
- Total connected load: 2.8 kW

**Oven type, heating type**

Built-in electric oven with 9 heating types:

- Conventional
- Grill
- Double grill
- Double grill with fan
- Bottom heat
- Conventional with fan
- Hot air
- Defrost
- ECO

**Design, comfort**

- Mechanical control with digital timer
- Fully retractable control knob
- Temperature regulation from 50 °C – 250 °C
- Full glass inner door
- Low window temperature
- Cooking chamber volume 93 l
- Smooth oven walls with suspended grates
- Metal handle
- Enamelled cooking chamber
- Removable oven door for easy cleaning
- Oven lighting
- Cooling fan
- Control lamp for operation condition

**Dimensions H × W × D**

- Appliance dimensions: 90.0 × 54.5 × 48.0 cm
- Installation dimensions: 47.5 – 47.7 × 86.0 × 55.0 – 56.0 cm



## Range Cooker

## 5RC 91490AU

**Output, consumption**

- Voltage: 220 – 240 V
- Total connected load: cooktop: 11.1 kW, oven: 2.94 kW

**Cooktop type, power**

Gas cooktop

5 SABAF burners with power:

- Central: 3.6 kW
- Front left: 3.0 kW
- Rear left: 1.75 kW
- Front right: 1.0 kW
- Rear right: 1.75 kW

Preset to natural gas (20 mbar)

- Can be converted to liquid gas (LPG nozzle is included in the package)
- Connection cable 1 m

**Oven type, heating type**

Built-in electric oven with 8 heating types:

- Hot air
- Bottom heat
- Conventional
- Convection with fan
- Grill
- Double grill
- Double grill with fan
- Defrost

**Environment, comfort**

- Mechanical control with digital timer
- Full glass inner door
- Enamelled cooking chamber
- Cooking chamber volume: 109 l
- Smooth oven walls with suspended grates
- Removable oven door for easy cleaning
- Oven lighting

**Dimensions H × W × D**

- Appliance dimensions: 76.9 × 89.5 × 60.0 cm



## Blaupunkt compact appliances – a wide variety of functions in the smallest of spaces

Cooking, braising, steaming – not only in large kitchens, but also in the smallest of spaces, Blaupunkt compact appliances offer the full range of functions while still leaving you plenty of space for cutting, seasoning and preparing.

Our space-saving multitasking appliances are real all-rounders and a smart addition for unused niches in larger kitchens.



Smart slider

### Smart slider

An intuitive, simple control concept for all appliances – every setting can be perfectly selected with the Smart Slider.



Touch control

### Touch Control

Precise, innovative and very user-friendly: gently touching the Touch Control buttons is enough to select the desired setting.



Automatic programmes

### Automatic programmes

One touch away from the perfect result: our automatic programmes are equipped for nearly every ingredient. Cooking can't get any easier.



Combined operations

### Combined operation

True all-rounders – our combination appliances! The little multitasking genius combines an oven function, a microwave and can even steam.



Steam food

### Steam cooking

Cooking with hot steam is gentle to the food, promises maximum taste and a healthy approach to your cooking.



Hot air

### Hot air

Optimum heat distribution allows you to achieve perfect baking and roasting results on up to three levels simultaneously. For energy-optimised baking and roasting on just one level, you can select the Hot Air Eco function.



# Fire



# Compact appliances

## Combination steam cooker

5C90S 8990GB New



### Output, consumption

- Voltage: 220 – 240 V
- Total connected load: 3.0 kW
- Grill output: 2,200 W / hot air output: 1,700 W

### Oven type, heating type

Compact oven with 13 heating types:

- Top / bottom heat
- Bottom heat
- Hot Air Eco
- Hot air
- Circulation
- Circulation grill
- Vario large area grill
- Vario small area grill
- Pizza level
- Defrost function
- Dough process
- Steam cooking from 35 °C – 100 °C
- Combined operation

### Design, comfort

- Control panel in the Dark Steel design
- Touch Control
- Smart Slider
- Digital display in white
- Push & pull water tank
- Temperature sensor
- Quick heating
- Temperature recommendation
- 16 automatic programmes
- Electronic temperature regulation from 30 °C – 250 °C
- Full glass inner door
- Dark Steel metal handle with logo
- Cooking chamber volume 50 l
- Flat oven walls with oven racks
- Enamelled cooking chamber
- Removable oven door for easy cleaning
- LED oven lighting
- Safety switch-off
- Child protection
- Cooling fan

### Dimensions H x W x D

- Appliance dimensions: 45.4 x 59.5 x 56.8 cm
- Installation dimensions: 45.0 x 56.0 x 55.0 cm
- Panel height: 96 mm



## Combination steam cooker

5KD 94150GB



### Output, consumption

- Voltage: 220 – 230 V
- Total connected load: 3.3 kW
- 900 W Microwave
- Grill output: 1,200 W / hot air output: 1,750 W
- Steam cooker output: 1,500 W

### Oven type, heating type

- Heating types: hot air, circulation grill, area grill, microwave, combined operation, steam function
- 5 output levels: 900 W, 700 W, 450 W, 300 W, 100 W
- Maximum temperature circulation / hot air: 230 °C
- Maximum temperature circulation grill: 180 °C
- Maximum temperature steam cooker: 100 °C
- Maximum temperature steam cooker / hot air: 230 °C

### Design, comfort

- Control panel made of glass and stainless steel
- 34 l stainless steel cooking chamber
- 1 l water tank volume for steam cooking function
- Metal handle
- Folding door
- Digital display
- Digital clock with day display
- All heating types can be used separately and in combination
- User-friendly electronics with touch control
- 10 defrost / cooking programmes with automatic weight adjustment
- Cook control – 80 automatic programmes
- Child protection

### Dimensions H x W x D

- Appliance dimensions: 45.4 x 59.5 x 52.5 cm
- Installation dimensions: 45.0 x 56.0 x 55.0 cm
- Panel height: 96 mm



## Built-in compact microwave oven

5MG 17190AU

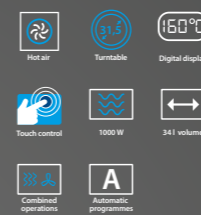

### Output, consumption

- Voltage: 230 – 240 V
- Connected load: 2.3 kW
- 1,000 W Microwave
- Grill Power: 1,100 W
- Hot air Power: 2,300 W

### Design, comfort

- Built-in appliance for a 60 cm wide tall cupboard
- Heating types: microwave, grill, hot air, combination cooking
- Touch control
- 5 output levels: 1,000 W, 800 W, 500 W, 300 W, 100 W
- 10 automatic programmes
- Defrost by weight / time
- Red LED Digital display
- 34 l stainless steel cavity
- 31.5 cm glass turntable
- Child safety lock
- Push open door

### Dimensions H x W x D

- Appliance dimensions: 38.8 x 59.5 x 47.0 cm
- Installation dimensions: 38.0 x 56.0 x 55.0 cm



## Built-in compact microwave oven

5MA 27500AU

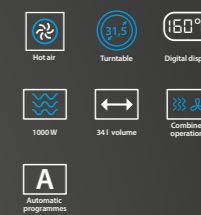

### Output, consumption

- Voltage: 230 – 240 V
- Connected load: 2.3 kW
- 1,000 W Microwave
- Grill Power: 1,100 W
- Hot air Power: 2,300 W

### Design, comfort

- Built-in microwave, stainless steel
- Heating types: microwave, grill, hot air, combination cooking
- Knob and button control
- 5 output levels: 1,000 W, 800 W, 500 W, 300 W, 100 W
- 10 automatic programmes
- Defrost by weight / time
- White LED digital display
- 34 l stainless steel cavity
- 31.5 cm glass turntable
- Child safety lock

### Dimensions H x W x D

- Appliance dimensions: 38.8 x 59.5 x 47.0 cm
- Installation dimensions: 38.0 x 56.0 x 55.0 cm





# Warming drawers and microwaves

## Warming drawer

### 5WS 16400



#### Output, consumption

- Voltage: 220 – 240 V
- Total connected load: 0.4 kW

#### Oven type, heating type

- Heating by fan heater
- Temperature regulation in 3 levels: from 30 °C – 80 °C
- 20.5 l interior volume
- Rotary switch on inside

#### Design, comfort

- Black glass front
- Opens without handles by push & pull
- Telescopic full extension
- Anti-slip mat
- Dish pre-heating
- Food warm-keeping function
- Defrosting of frozen food
- Load capacity 15 kg

#### Dimensions H × W × D

- Appliance dimensions: 14.0 × 59.4 × 54.2 cm
- Installation dimensions: 14.0 × 56.0 – 56.8 × 55.0 cm



## Warming drawer

### 5WS 16401



#### Output, consumption

- Voltage: 220 – 240 V
- Total connected load: 0.4 kW

#### Oven type, heating type

- Heating by fan heater
- Temperature regulation in 3 levels: from 30 °C – 80 °C
- 20.5 l interior volume
- Rotary switch on inside

#### Design, comfort

- Black glass front with stainless steel screen
- Opens without handles by push & pull
- Telescopic full extension
- Anti-slip mat
- Dish pre-heating
- Food warm-keeping function
- Defrosting of frozen food
- Load capacity 15 kg

#### Dimensions H × W × D

- Appliance dimensions: 14.0 × 59.4 × 54.2 cm
- Installation dimensions: 14.0 × 56.0 – 56.8 × 55.0 cm



## Blaupunkt hobs – heat that makes a point

Not all heat is alike. Sometimes the temperature has to rise rapidly – boosting heat for perfect searing. Other things need time – uniform heat for gentle cooking.



### Smart slider

An intuitive, simple control concept for all appliances – every setting can be perfectly selected with the Smart Slider.



### Touch Control

Precise, innovative and very user-friendly: gently touching the Touch Control buttons is enough to select the desired setting.



### Induction

#### Induction

Immediately hot, immediately cold, and nothing gets burnt. The base of the pan is directly heated by the induction coil. The heat is only produced where it is needed. This means short heat-up times, more safety and much less energy consumption.



### Combi induction

#### Combi induction

Two induction cooking zones can be combined together to create one single cooking zone, thereby allowing the use of very large pots and pans. Of course, the two large cooking zones can also be used separately.



### Boost function

#### Boost function

No long heat-up times: the right cooking temperature is reached in seconds with the boost function.



### Multi control

#### Multi Control

The extractor fan hood and hob are intelligently linked. The extractor fan hood can be controlled separately using the hob control panel and automatically adjusts the fan power to the heat generated. The colour temperature and light intensity are individually controlled via the intelligent light system.



# Heat



## Stand-alone hob, combi induction

511 94291 New



- New design
- Grill function
- White display
- Smart Slider
- Enhanced technology

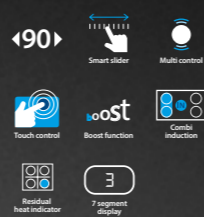

## Output, consumption

- Voltage: 220 – 240V
- Total connected load: 7.4 kW
- 5 induction cooking zones with booster:
  - 2 cooking zones, combi induction  
Ø 20.0 × 21.0 cm, 2.3 kW (3.0 kW)
  - 2 cooking zones, combi induction  
Ø 20.0 × 21.0 cm, 2.3 kW (3.0 kW)
  - 1 cooking zone Ø 21.5 cm, 2.3 kW (3.0 kW)

## Design, comfort

- Frameless
- Multi Control
- Smart Slider
- Touch Control
- 2 × combi induction
- Flexible linking – Any two cooking zones can be combined into one cooking zone
- Boost function for all induction cooking zones
- Grill function
- Electronic control in 10 power levels
- Digital display of cooking levels in white
- Residual heat display for each cooking zone
- Pot detection
- Child protection
- Timer – simultaneously adjustable for each cooking zone
- Countdown function
- Quick start function
- Recall function – Repeat the last settings
- Automatic safety switch-off
- Overflow detection
- Power management
- Flush-mounted installation possible
- Quick assembly system

## Dimensions H × W × D

- Appliance dimensions: 5.2 × 88.0 × 52.0 cm
- Installation dimensions: 5.2 × 81.0 × 49.0 cm

It's every barbecue fan's dream: It may be raining, snowing or stormy outside – he can still indulge his passion inside. With the cast iron grill plate or the new cast iron Teppanyaki plate, steaks, fish and vegetables get that familiar aroma from the open-air barbecue season.



## PLENTY OF SPACE

Large area for preparing large quantities



## LOW FAT – GREAT TASTE

Healthy preparation – the optimised surface allows excess oil to drain off and requires little cooking fat



## FLEXIBILITY IN ALL AREAS

Diverse possibilities – vegetables, meat, fish and much more

UNIFORMITY  
RIGHT DOWN THE LINE

Constant heat even with large quantities of food



## HEAT TO PERFECTION

The temperature can be set and maintained exactly, thus preventing burning and rapid drying



## EASY TO CLEAN

The smooth surface allows easy and quick cleaning after use

## Cast iron grill plate

5Z 99GP01



## Cast iron Teppanyaki plate

5Z 99TP01 New



## Stand-alone hob, induction

5IE 84252 New

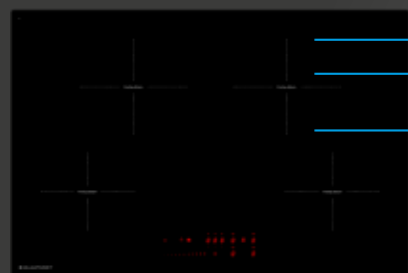

Smart Slider  
Quick  
assembly  
Enhanced  
technology

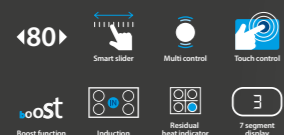
**Output, consumption**

- Voltage: 220–240 V
- Total connected load: 7.4 kW
- 4 induction cooking zones with booster:
  - 2 cooking zones Ø 17.5 cm, 1.4 kW (2.1 kW)
  - 2 cooking zones Ø 21.5 cm, 2.3 kW (3.0 kW)

**Design, comfort**

- Frameless
- Multi Control
- Smart Slider
- Touch Control
- Boost function for all induction cooking zones
- Electronic control in 10 power levels
- Digital display of cooking levels
- Residual heat display for each cooking zone
- Pot detection
- Child protection
- Timer – simultaneously adjustable for each cooking zone
- Countdown function
- Quick start function
- Recall function – Repeat the last settings
- Automatic safety switch-off
- Overflow detection
- Power management
- Flush-mounted installation possible
- Quick assembly system

**Dimensions H × W × D**

- Appliance dimensions: 5.2 × 78.0 × 52.0 cm
- Installation dimensions: 5.2 × 75.0 × 49.0 cm



## Stand-alone hob, induction

5IE 64252 New

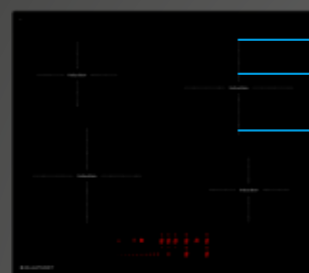

Smart Slider  
Quick  
assembly  
Enhanced  
technology

**Output, consumption**

- Voltage: 220–240 V
- Total connected load: 7.4 kW
- 4 induction cooking zones with booster:
  - 1 cooking zone Ø 15.5 cm, 1.4 kW (2.1 kW)
  - 1 cooking zone Ø 15.5 cm, 1.4 kW (1.85 kW)
  - 2 cooking zones Ø 21.5 cm, 2.3 kW (3.0 kW)

**Design, comfort**

- Frameless
- Multi Control
- Smart Slider
- Touch Control
- Boost function for all induction cooking zones
- Electronic control in 10 power levels
- Digital display of cooking levels
- Residual heat display for each cooking zone
- Pot detection
- Child protection
- Timer – simultaneously adjustable for each cooking zone
- Countdown function
- Quick start function
- Recall function – Repeat the last settings
- Automatic safety switch-off
- Overflow detection
- Power management
- Flush-mounted installation possible
- Quick assembly system

**Dimensions H × W × D**

- Appliance dimensions: 5.2 × 59.0 × 52.0 cm
- Installation dimensions: 5.2 × 56.0 × 49.0 cm

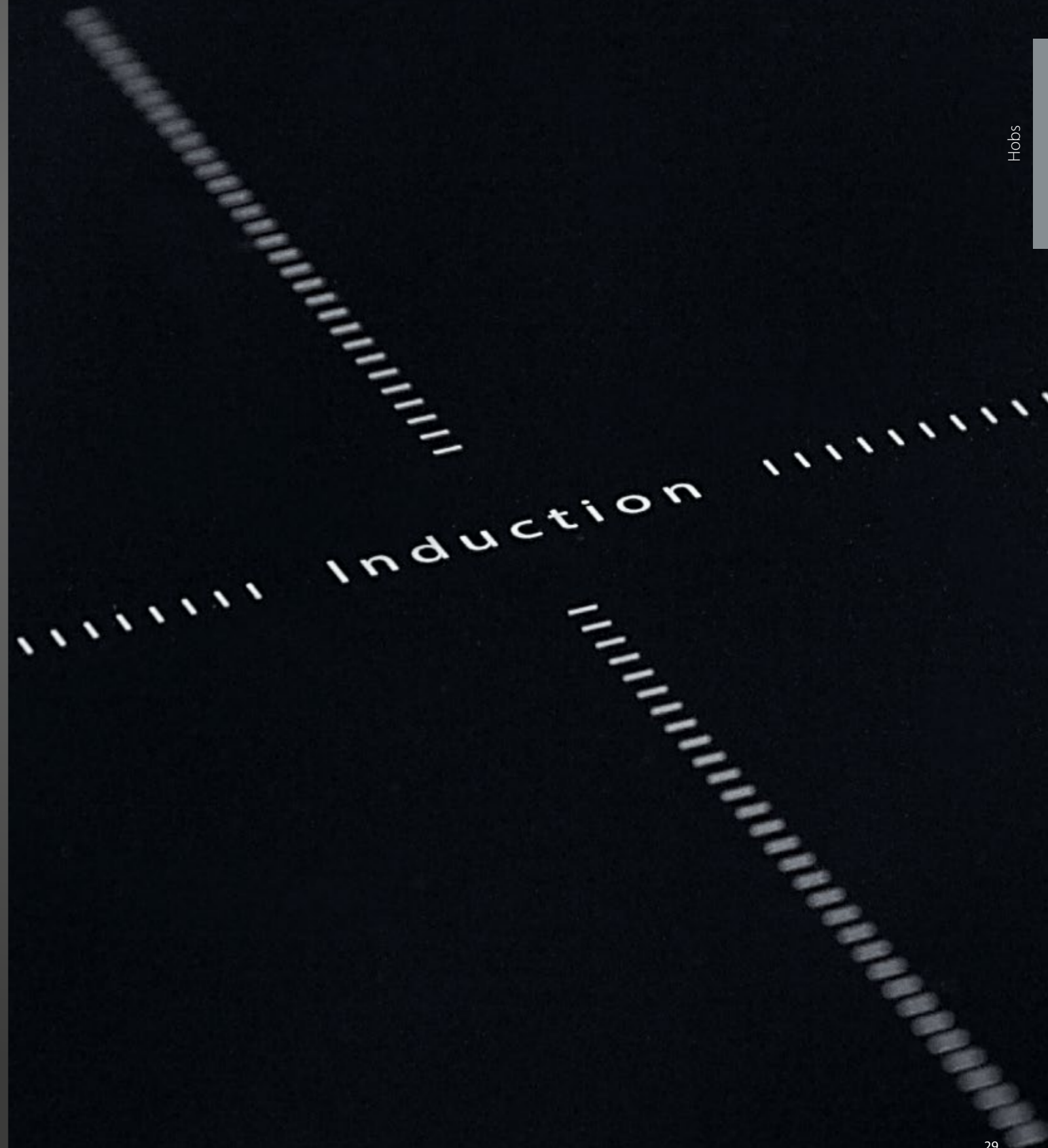

## Stand-alone hob

5RG 74351 New

**Output, consumption**

- Voltage: 220 – 240 V
- Total connected load: 7.0 kW
- 4 high-speed cooking zones:
  - 1 cooking zone Ø 14.5 / 22.0 cm, 1.0 kW (2.2 kW) double ring zone
  - 1 cooking zone Ø 18.0 / 27.5 cm, 1.5 kW (2.4 kW) casserole zone
  - 2 cooking zones Ø 15.5 cm, 1.2 kW

**Design, comfort**

- Frameless
- Touch Control
- Sensor button for zone extension
- Electronic control in 10 power levels
- Digital display of cooking levels
- Residual heat display for each cooking zone
- Child lock
- Timer – simultaneously adjustable for each cooking zone
- Automatic safety switch-off
- Overflow detection
- Flush-mounted installation possible
- Quick assembly system

**Dimensions H x W x D**

- Appliance dimensions: 5.7 x 78.0 x 52.0 cm
- Installation dimensions: 5.7 x 75.0 x 49.0 cm



## Stand-alone hob

5RG 64361 New

**Output, consumption**

- Voltage: 220 – 240 V
- Total connected load: 7.0 kW
- 4 high-speed cooking zones:
  - 1 cooking zone Ø 14.5 / 22.0 cm, 1.0 kW (2.2 kW) double ring zone
  - 1 cooking zone Ø 18.0 / 27.5 cm, 1.5 kW (2.4 kW) casserole zone
  - 2 cooking zones Ø 15.5 cm, 1.2 kW

**Design, comfort**

- Frameless
- Touch Control
- Sensor button for zone extension
- Electronic control in 10 power levels
- Digital display of cooking levels
- Residual heat display for each cooking zone
- Child lock
- Timer – simultaneously adjustable for each cooking zone
- Automatic safety switch-off
- Overflow detection
- Flush-mounted installation possible
- Quick assembly system

**Dimensions H x W x D**

- Appliance dimensions: 5.7 x 59.0 x 52.0 cm
- Installation dimensions: 5.7 x 56.0 x 49.0 cm



## Stand-alone hob

5RE 64361 New

**Output, consumption**

- Voltage: 220 – 240 V
- Total connected load: 6.0 kW
- 4 high-speed cooking zones:
  - 2 cooking zones Ø 15.5 cm, 1.2 kW
  - 2 cooking zones Ø 19.0 cm, 1.8 kW

**Design, comfort**

- Frameless
- Touch Control
- Electronic control in 10 power levels
- Digital display of cooking levels
- Residual heat display for each cooking zone
- Child lock
- Automatic safety switch-off
- Overflow detection
- Flush-mounted installation possible
- Quick assembly system

**Dimensions H x W x D**

- Appliance dimensions: 5.7 x 59.0 x 52.0 cm
- Installation dimensions: 5.7 x 56.0 x 49.0 cm



## Stand-alone hob

5RZ 34411 New

**Output, consumption**

- Voltage: 220 – 240 V
- Total connected load: 3.0 kW
- 2 high-speed cooking zones:
  - 1 cooking zone Ø 14.5 cm, 1.2 kW
  - 1 cooking zone Ø 18.0 cm, 1.8 kW

**Design, comfort**

- Frameless
- Touch Control
- Electronic control in 9 power levels
- Digital display of cooking levels
- Residual heat display for each cooking zone
- Child lock
- Automatic safety switch-off
- Overflow detection
- Flush-mounted installation possible
- Quick assembly system

**Dimensions H x W x D**

- Appliance dimensions: 5.7 x 29.0 x 52.0 cm
- Installation dimensions: 5.7 x 27.0 x 49.0 cm





# Heat

## Blaupunkt gas hobs – heat in its most original form

Change the temperature at lightning speed – cooking on an open flame is direct, emotional and, thanks to the latest technology, completely safe. A Blaupunkt gas hob is an eye-catcher in the kitchen and delivers a truly professional cooking experience.

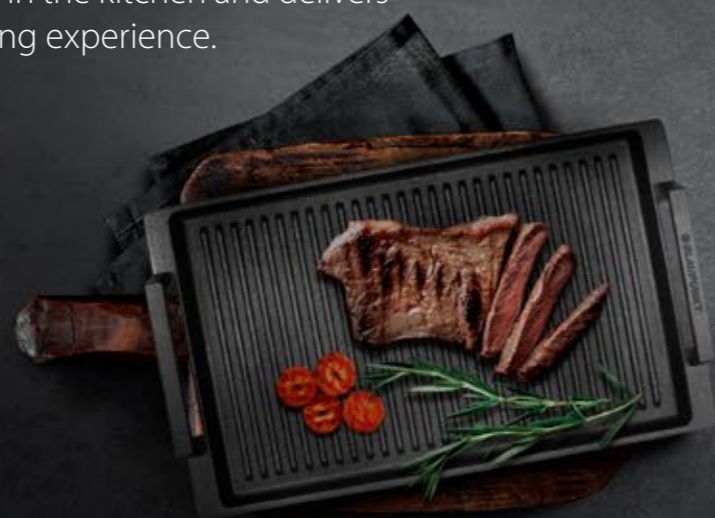



# Gas hobs

## Gas hob

5GB 62191AU New



◀60▶

### Output, consumption

- Connected load, gas: 8.1 kW
- Burner with 4 cooking areas:
- Front left: Triple burner 3.6 kW
- Back left: Standard burner 1.75 kW
- Rear right: Standard burner 1.75 kW
- Front right: Economy burner 1 kW

### Design, comfort

- Black glass, hardened
- Front control knob
- Electrical spoke spark ignition controllable with one hand
- Protection against unintentional escape of gas (thermoelectric safety pilot)
- Cast iron pot carrier
- Preset to natural gas (20 mbar)
- Convertible to liquid gas (LPG nozzle is included in the package)
- Connection cable 1 m

### Dimensions H × W × D

- Appliance dimensions: 9.0 × 60.0 × 51.5 cm
- Installation dimensions: 4.5 × 56.0 × 49.0 cm



## Gas hob

5GB 72290AU New



◀75▶

### Output, consumption

- Connected load, gas: 11.1 kW
- Burner with 5 cooking areas:
- Front left: Economy burner 1 kW
- Back left: Rapid burner 3 kW
- Mid: wok burner: 3.6 kW
- Rear right: Standard burner 1.75 kW
- Front right: Standard burner 1.75 kW

### Design, comfort

- Black glass, hardened
- Front control knob
- Electrical spoke spark ignition controllable with one hand
- Protection against unintentional escape of gas (thermoelectric safety pilot)
- Cast iron pot carrier
- Preset to natural gas (20 mbar)
- Convertible to liquid gas (LPG nozzle is included in the package)
- Connection cable 1 m

### Dimensions H × W × D

- Appliance dimensions: 9.0 × 75.0 × 52.0 cm
- Installation dimensions: 4.5 × 56.0 × 49.0 cm



## Gas hob

5GB 61151AU New



◀60▶

### Output, consumption

- Connected load, gas: 8.1 kW
- Burner with 4 cooking areas:
- Front left: Triple burner 3.6 kW
- Back left: Standard burner 1.75 kW
- Rear right: Standard burner 1.75 kW
- Front right: Economy burner 1 kW

### Design, comfort

- Stainless steel
- Front control knob
- Electrical spoke spark ignition controllable with one hand
- Protection against unintentional escape of gas (thermoelectric safety pilot)
- Cast iron pot carrier
- Preset to natural gas (20 mbar)
- Convertible to liquid gas (LPG nozzle is included in the package)
- Connection cable 1 m

### Dimensions H × W × D

- Appliance dimensions: 9.0 × 59.0 × 51.0 cm
- Installation dimensions: 4.5 × 56.0 × 49.0 cm



## Gas hob

5GB 91250AU

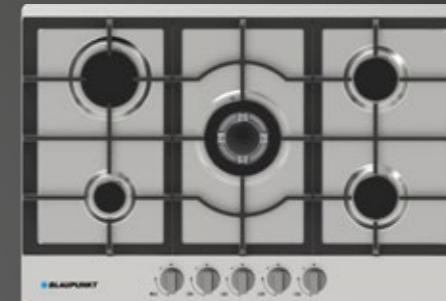

◀90▶

### Output, consumption

- Connected load, gas: 11.1 kW
- Burner with 5 cooking areas:
- Front left: Economy burner 1 kW
- Back left: Rapid burner 3 kW
- Mid: wok burner: 3.6 kW
- Rear right: Standard burner 1.75 kW
- Front right: Standard burner 1.75 kW

### Design, comfort

- Stainless steel
- Front control knob
- Electrical spoke spark ignition controllable with one hand
- Protection against unintentional escape of gas (thermoelectric safety pilot)
- Cast iron pot carrier
- Preset to natural gas (20 mbar)
- Can be converted to liquid gas (LPG nozzle is included in the package)
- Connection cable 1 m

### Dimensions H × W × D

- Appliance dimensions: 9.0 × 86.0 × 51.0 cm
- Installation dimensions: 4.5 × 81.5 × 49.0 cm



# Heat Air



Blaupunkt hob with integrated extractor – remove the fumes right where they arise

The modern extractor solution offers one thing above all – more freedom: A clear view, as the fumes are extracted directly where they arise. Odourless cooking and more freedom in kitchen planning.

High-quality filter systems allow nothing but fresh air to be produced, while still being powerful and noise-free. The perfect combination of heat and air in a single appliance.



Smart slider

#### Smart Slider

An intuitive, simple control concept for all appliances – every setting can be perfectly selected with the Smart Slider.



Touch control

#### Touch Control

Precise, innovative and very user-friendly: gently touching the Touch Control buttons is enough to select the desired setting.



Induction

#### Induction

Immediately hot, immediately cold, and nothing gets burnt. The base of the pan is directly heated by the induction coil. The heat is only produced where it is needed. This means short heat-up times, more safety and much less energy consumption.



Combi induction

#### Combi induction

Two induction cooking zones can be combined together to create one single cooking zone, thereby allowing the use of very large pots and pans. Of course, the two large cooking zones can also be used separately.



# Hob with extractor fan

## Perfectly planned – Hob with an extractor fan

Perfect integration in the kitchen cabinet makes integrated design and maximum functionality possible in the first place. Thanks to the slim and space-efficient design, the appliances allow a greater use of your cabinet and drawer spaces.

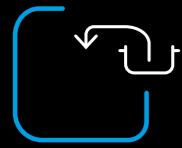

### SHORTER DISTANCE – MORE EFFICIENT EXTRACTION – FRESHER AIR

The downdraft extractor ensures that cooking fumes do not even escape to the room and are instead filtered directly.

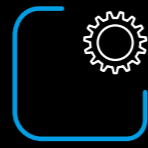

### EFFICIENT TECHNOLOGY – MAXIMIZED PERFORMANCE

Optimized extraction paths, powerful motors and a perfectly balanced flow rate ensure maximum performance.



### BETTER POSITIONING – ENJOYABLE COOKING

The intelligent fusion of a hob and extractor fan saves you from an unfavourable eye-level appliance position. Thanks to the direct downdraft extraction of the fumes, you keep a clear view.



### RELAXING COOKING EXPERIENCE

Installation at base height shifts the sound field from the eye level downwards. Especially quiet motors give you additional peace and quiet.



### FEWER APPLIANCES – PLANNING WITHOUT LIMITS

The absence of the additional appliance at head height opens up new possibilities in kitchen planning. Positioning the hob in the centre of the room or directly in front of the window allows you a clear view: no more limits stand in your way.



### QUALITY FROM SELECTION TO WORKMANSHIP

Functionality and longevity are the result of the use of high-quality materials and precise workmanship.



### EASIER TO ACCESS – EASIER TO CLEAN

The filter technology ensures excellent absorption of moisture. To clean, you can access the filters easily and practically from above, rendering a tedious disassembly unnecessary.



Here you can find all information about our hob fans.

#### Stand-alone hob, induction with integrated extractor fan

## 5IX 99290AU

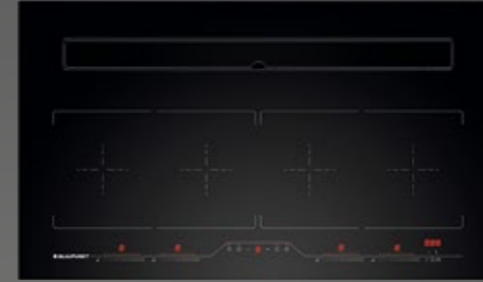

#### Output, consumption – hob

- Voltage: 220–240 V
- Total connected load: 8.8 kW
- 4 induction cooking zones with booster:
- 4 cooking zones Ø 22 cm, 2.1 kW (3.7 kW)

#### Design, comfort – hob

- Frameless
- Touch control with Smart Slider
- Boost function for all induction cooking zones
- Electronic control in 10 power levels
- Main switch for hob and extractor fan
- Toggle function with fixed temperatures (40 °C, 70 °C und 98 °C)
- Cooking Chef Mode, Pause and Recall
- Residual heat display
- Pot detection
- Child lock
- Timer
- Countdown function
- 2 × bridging function
- Flush-mounted installation possible

#### Dimensions H × W × D

- Appliance dimensions: 82.7–98.2 × 90 × 53 cm
- Installation dimensions: 5.8 × 86.2 × 49.5 cm

#### Planning information

- Air outlet/exhaust air duct to the left
- It is not possible to plan in dishwashers, underframe coolers, base drawers, etc. in the exhaust air routing area
- For the circulation variant, it is not possible to plan in dishwashers, underframe coolers, base drawers, etc. directly on the left side
- Min. cabinet width 900 mm
- Worktop depth min. 600 mm (correspondingly deeper for the planning of recess panelling)
- Base height min. 100 mm

#### Output, consumption – extractor fan

- Voltage: 220–240 V
- Total connected load: 165 W
- Average power consumption: 30.8 kWh/year
- Noise min./max. normal level/intensive level: min 45 dB (A) max. 65 dB (A) max. 70 dB (A)
- Fan output max. normal level/intensive level\*: In extraction mode 580 m<sup>3</sup>/h/730 m<sup>3</sup>/h In circulation mode 45 m<sup>3</sup>/h/560 m<sup>3</sup>/h

#### Design, comfort – extractor fan

- Electronic opening of the extractor fan
- Glass ceramic, black
- Suitable for installation in a kitchenette or kitchen island
- Optional extraction or circulation mode (for circulation mode a carbon filter is required)
- 6-level fan output controllable via Touch Control with 7-segment LED display
- 5 power levels + 1 intensive level
- Intensive level with automatic reset for extraction mode
- Automatic three-level blower overrun of 5/10 and 20 minutes with LED display
- Metallic grease filter and carbon filter saturation indicator via LED warning light
- For the cleaning/emptying of metallic filters and water collection vessels, the appliance automatically blocks after 40 hours of operation
- Automatic overrun for circulation mode
- Water collection tank: 0.75 litre capacity
- Powerful and quiet blower
- Metallic grease filter, dishwasher-safe



\* According to EU Regulation no. 65/2014/fan power according to EN 61591

# Multi Control



# Blaupunkt Multi Control – a unique connection



Here everything comes together that belongs together: Blaupunkt hobs with Multi Control  form a unique combination – together with the Multi Control extractor fan hoods. These can be easily controlled using the hob operating panel, and they automatically adjust their output in line with the heat generation of the hob. The cable-free Multi Control sensor promises a long-lasting technical standard and intuitive operation.

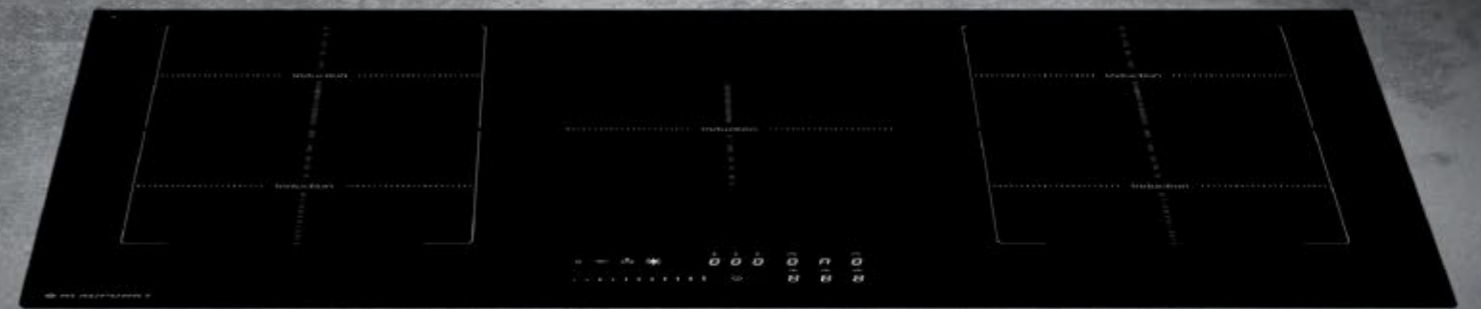



# Extractor fan hoods

## Ceiling fan

### 5DD 72555AU New



#### Output, consumption

- Voltage: 220 – 240 V
- Total connected load: 150.4 W
- Average power consumption: 38.3 kWh / year\*
- Fan efficiency class: A\*
- Light efficiency class: B\*
- Grease filter efficiency class: E\*
- Noise min. / max. Normal level: 40 / 65 dB\*

Fan output max. Normal level / Intensive level\*:

- In extraction mode 490 m<sup>3</sup> / h / 700 m<sup>3</sup> / h
- In circulation mode 300 m<sup>3</sup> / h / 400 m<sup>3</sup> / h

#### Design, comfort

- Stainless steel
- For ceiling installation above kitchen islands
- Multi Control
- Optional extraction or circulation mode (carbon filter required for circulation mode)
- Electronic control
- 4-level fan power (3 power levels + 1 intensive level) controllable through Multi Control
- Intensive levels with automatic reset
- Filter saturation display
- Powerful and quiet blower
- Uniform, bright lighting with 2 × 2.7 W LED modules
- Optional extendible Multi Control function: LED light with adjustable brightness and colour temperature
- Illuminance: 111 Lux
- Colour temperature: 4,000 K preset
- Metal grease filter, dishwasher-safe

#### Dimensions H × W × D

- Appliance dimensions: max. 19.2 × 90.0 × 49.9 cm



## Wall hood

### 5DB 69253AU



#### Output, consumption

- Voltage: 220 – 240 V
  - Total connected load: 225.4 W
  - Average power consumption: 44 kWh / year\*
  - Noise min. / max. normal level: 48 / 58 dB\*
- Fan output max. normal level / intensive level\*:
- In extraction mode 560 m<sup>3</sup> / h / 632 m<sup>3</sup> / h
  - In circulation mode 394 m<sup>3</sup> / h / 445 m<sup>3</sup> / h

#### Design, comfort

- Stainless steel
- For wall installation above cooking zones
- Multi Control
- Optional extraction or circulation mode (for circulation mode a carbon filter is required)
- Electronic control
- 4-level fan output (3 power levels + 1 intensive level) controllable via Multi Control
- Intensive levels with automatic reset
- Powerful and quiet blower
- Uniform, bright lighting with 2 × 2.7 W LED modules
- Optional extendible Multi Control function: LED light with adjustable brightness and colour temperature
- Heat sensor for automatic mode
- Colour temperature 4,000 K preset
- Metallic grease filter, dishwasher-safe
- Incl. exhaust air shaft

#### Dimensions H × W × D

- Appliance dimensions, extraction: 64.0 – 106.0 × 90.0 × 48.0 cm
- Appliance dimensions, circulation: 71.0 – 113.0 × 90.0 × 48.0 cm



## Wall hood

### 5DW 69750AU

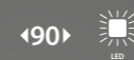

#### Output, consumption

- Voltage: 220 – 240 V
- Total connected load: 135 W
- Average power consumption: 72.5 kWh / year\*
- Fan efficiency class: E\*
- Light efficiency class: A\*
- Grease filter efficiency class: C\*
- Noise min. / max. Normal level: 53 / 64 dB\*

Fan output max. Normal level:

- In extraction mode max. 380 m<sup>3</sup> / h
- In circulation mode max. 235 m<sup>3</sup> / h

#### Design, comfort

- Stainless steel
- For wall installation above cooking zones
- Optional extraction or circulation mode (carbon filter required for circulation mode)
- 3-level fan power controllable via push buttons
- Uniform, bright lighting with 2 × 5 W LED lamps
- Illuminance: 900 Lux
- Colour temperature: 3,000 K
- Metal grease filter, dishwasher-safe
- Incl. exhaust air shaft

#### Dimensions H × W × D

- Appliance dimensions, extraction: 66.0 – 101.5 × 90.0 × 47.0 cm
- Appliance dimensions, circulation: 79.0 – 101.5 × 90.0 × 47.0 cm



## Wall hood

### 5DW 66750AU



#### Output, consumption

- Voltage: 220 – 240 V
- Total connected load: 135 W
- Average power consumption: 72.5 kWh / year\*
- Fan efficiency class: E\*
- Light efficiency class: A\*
- Grease filter efficiency class: C\*
- Noise min. / max. Normal level: 53 / 64 dB\*

Fan output max. Normal level:

- In extraction mode max. 380 m<sup>3</sup> / h
- In circulation mode max. 235 m<sup>3</sup> / h

#### Design, comfort

- Stainless steel
- For wall installation above cooking zones
- Optional extraction or circulation mode (carbon filter required for circulation mode)
- 3-level fan power controllable via push buttons
- Uniform, bright lighting with 2 × 5 W LED lamps
- Illuminance: 900 Lux
- Colour temperature: 3,000 K
- Metal grease filter, dishwasher-safe
- Incl. exhaust air shaft

#### Dimensions H × W × D

- Appliance dimensions, extraction: 66.0 – 101.5 × 60.0 × 47.0 cm
- Appliance dimensions, circulation: 79.0 – 101.5 × 60.0 × 47.0 cm



\* According to EU Regulation no. 65 / 2014 / fan power according to EN 61591

# Extractor fan hoods

## Flat hood

### 5DA 36258AU



#### Output, consumption

- Voltage: 220 – 240 V
  - Total connected load: 118 W
  - Average power consumption: 38.6 kWh/year\*
  - Noise min./max. normal level: 54/67 dB\*
- Fan power\*
- In extraction mode max. 340 m<sup>3</sup>/h
  - In circulation mode max. 120 m<sup>3</sup>/h

#### Design, comfort

- Optional extraction or circulation mode (activated carbon filter required for circulation mode)
- For wall cabinet 60 cm
- Telescopic extension without panel
- Panel from original light strip from kitchen furniture manufacturer
- 3-level fan output controllable via slide switch
- Automatic switch-on and switch-off by pressing the moving filter surface
- Uniform, bright lighting with 2 × 4 W LED lamps
- Illuminance: 100 Lux
- Colour temperature 3,000 K
- Metallic grease filter, dishwasher-safe

#### Dimensions H × W × D

- Appliance dimensions: 19.6 × 59.8 × 26.0 cm



## Flat hood

### 5DA 39258AU

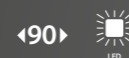

#### Output, consumption

- Voltage: 220 – 240 V
  - Total connected load: 118 W
  - Average power consumption: 38.6 kWh/year\*
  - Noise min./max. normal level: 54/67 dB\*
- Fan power\*
- In extraction mode max. 340 m<sup>3</sup>/h
  - In circulation mode max. 120 m<sup>3</sup>/h

#### Design, comfort

- Optional extraction or circulation mode (activated carbon filter required for circulation mode)
- For wall cabinet 90 cm
- Telescopic extension without panel
- Panel from original light strip from kitchen furniture manufacturer
- 3-level fan output controllable via slide switch
- Automatic switch-on and switch-off by pressing the moving filter surface
- Uniform, bright lighting with 2 × 4 W LED lamps
- Illuminance: 100 Lux
- Colour temperature 3,000 K
- Metallic grease filter, dishwasher-safe

#### Dimensions H × W × D

- Appliance dimensions: 19.8 × 89.8 × 28.0 cm



## Fan module

### 5DA 45450AU



#### Output, consumption

- Voltage: 220 – 240 V
  - Total connected load: 254 W
  - Average power consumption: 96.1 kWh/year\*
  - Fan efficiency class: A\*
  - Light efficiency class: A\*
  - Grease filter efficiency class: C\*
  - Noise min./max. Normal level: 57/71 dB\*
- Fan output max. Normal level/Intensive level\*:
- In extraction mode 600 m<sup>3</sup>/h/680 m<sup>3</sup>/h
  - In circulation mode 290 m<sup>3</sup>/h/340 m<sup>3</sup>/h

#### Design, comfort

- Fan module with white glass
- Optional extraction or circulation mode (carbon filter required for circulation mode)
- Soft push buttons (3 power levels + 1 intensive level)
- Intensive levels with automatic reset
- High, fine-tunable fan power through electronic control
- Edge suction
- Uniform, bright lighting with 2 × 1 W LED lamps
- Illuminance: 200 Lux
- Colour temperature: 3,000 K
- Metal grease filter, dishwasher-safe

#### Special accessories

- 5Z 9100X1: Activated carbon filter

#### Dimensions H × W × D

- Appliance dimensions, extraction: 33.0 × 52.0 × 30.0 cm
- Appliance dimensions, circulation: 33.0 × 52.0 × 30.0 cm



## Fan module

### 5DA 49450AU



#### Output, consumption

- Voltage: 220 – 240 V
  - Total connected load: 254 W
  - Average power consumption: 96.1 kWh/year\*
  - Noise min./max. normal level: 57/71 dB\*
- Fan output max. normal level/intensive level\*:
- In extraction mode 600 m<sup>3</sup>/h/680 m<sup>3</sup>/h

#### Design, comfort

- Fan module with white glass
- Optional extraction or circulation mode (starter set required for circulation mode)
- Soft push buttons (3 power levels + 1 intensive level)
- Intensive levels with automatic reset
- High, fine-tunable fan output via electronic control
- Edge suction
- Uniform, bright lighting with 2 × 1 W LED lamps
- Illuminance: 200 Lux
- Colour temperature 3,000 K
- Metallic grease filter, dishwasher-safe

#### Dimensions H × W × D

- Appliance dimensions, extraction: 33.0 × 86.0 × 30.0 cm
- Appliance dimensions, circulation: 33.0 × 86.0 × 30.0 cm



\* According to EU Regulation no. 65 / 2014 / fan power according to EN 61591



# Extractor fan hoods

## Fan module

### 5DA 15250AU



#### Output, consumption

- Voltage: 220–240 V
- Total connected load: 118 W
- Average power consumption: 44.7 kWh/year\*
- Noise min./max. normal level: 54/70 dB(A)\*
- Fan output max. normal level/intensive level\*:
- In extraction mode max. 390 m<sup>3</sup>/h
- In circulation mode max. 120 m<sup>3</sup>/h

#### Design, comfort

- Optional extraction or circulation mode (starter set required for circulation mode)
- For wall cabinet 60 cm
- Fan power 3-level adjustable by speed sliding switch
- Powerful and quiet blower
- Even, bright illumination with 2 × 4 W LED lamps
- Illuminance: 100 Lux
- Color temperature: 3,000 K
- Metallic grease filter, dishwasher-safe (aluminium)

#### Dimensions H × W × D

- Appliance dimensions: 21.4 × 52.2 × 28.6 cm



## Fan module

### 5DA 17250AU

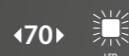

#### Output, consumption

- Voltage: 220–240 V
- Total connected load: 118 W
- Average power consumption: 44.7 kWh/year\*
- Noise min./max. normal level: 54/70 dB\*
- Fan output max. normal level/intensive level\*:
- In extraction mode max. 390 m<sup>3</sup>/h
- In circulation mode max. 120 m<sup>3</sup>/h

#### Design, comfort

- Optional extraction or circulation mode (starter set required for circulation mode)
- For wall cabinet 90 cm
- Fan power 3-level adjustable by speed sliding switch
- Powerful and quiet blower
- Even, bright illumination with 2 × 4 W LED lamps
- Illuminance: 100 Lux
- Colour temperature: 3,000 K
- Metallic grease filter, dishwasher-safe (aluminium)

#### Dimensions H × W × D

- Appliance dimensions: 21.4 × 70.2 × 28.6 cm



## Fan module

### 5DA 15151AU

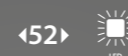

#### Output, consumption

- Voltage: 220–240 V
- Total connected load: 118 W
- Average power consumption: 44.7 kWh/year\*
- Noise min./max. normal level: 54/70 dB(A)\*
- Fan output max. normal level/intensive level\*:
- In extraction mode max. 390 m<sup>3</sup>/h
- In circulation mode max. 12 m<sup>3</sup>/h

#### Design, comfort

- Optional extraction or circulation mode (starter set required for circulation mode)
- For wall cabinet 60 cm
- Fan power 3-level adjustable by speed sliding switch
- Powerful and quiet blower
- Even, bright illumination with 2 × 4 W LED lamps
- Illuminance: 100 Lux
- Color temperature: 3,000 K
- Metallic grease filter, dishwasher-safe (aluminium)

#### Dimensions H × W × D

- Appliance dimensions: 21.4 × 52.2 × 28.6 cm



## Fan module

### 5DA 17151AU



#### Output, consumption

- Voltage: 220–240 V
- Total connected load: 118 W
- Average power consumption: 44.7 kWh/year\*
- Noise min./max. normal level: 54/70 dB\*
- Fan output max. normal level/intensive level\*:
- In extraction mode max. 390 m<sup>3</sup>/h
- In circulation mode max. 120 m<sup>3</sup>/h

#### Design, comfort

- Optional extraction or circulation mode (starter set required for circulation mode)
- For wall cabinet 90 cm
- Fan power 3-level adjustable by speed sliding switch
- Powerful and quiet blower
- Even, bright illumination with 2 × 4 W LED lamps
- Illuminance: 100 Lux
- Colour temperature: 3,000 K
- Metallic grease filter, dishwasher-safe (aluminium)

#### Dimensions H × W × D

- Appliance dimensions: 21.4 × 70.2 × 28.6 cm



# Water

## Blaupunkt dishwashers – the washing-up is part of the fun

First the pleasure, then the work? Blaupunkt dishwashers do the work on your behalf to ensure that the pleasure continues past the meal. Various installation heights and widths. And variable storage space – the Blaupunkt programme offers the perfect aide for every space requirement.



Aquastop

### Aquastop

A lifelong guarantee against water damage. The Aquastop safety system prevents all types of water damage – whether to the supply hose or through a leak in the appliance.



Extra silent

### Extra quiet

More durable, efficient and particularly quieter motor.



Vario basket

### Vario basket

The upper basket is height-adjustable and may be equipped with up to two racks depending on the model. The lower basket has two folding spine rows.



Digital display

### Digital display

A digital display gives you a good overview of the selected programme and the cycle time.

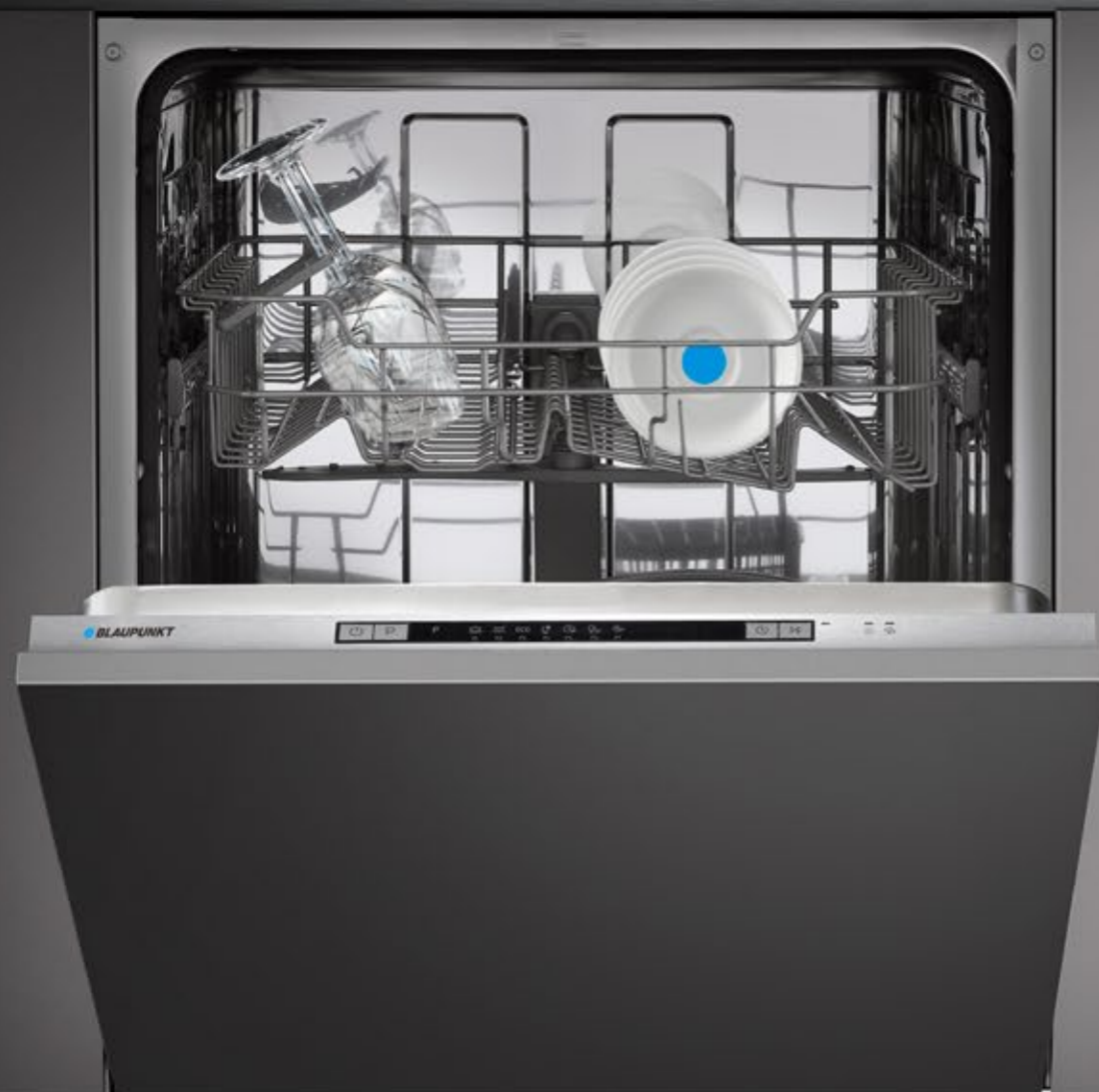



# Dishwashers

## Built-in dishwasher, semi integrated

### 5VI 310AU



#### Output, consumption

- Energy efficiency class: 3 star
- Water consumption class: 4.5 star
- Capacity: 12 standard place settings
- Energy / water<sup>1)</sup>: 199 kWh / 2,940 l
- Energy / water<sup>2)</sup>: 0.71 kWh / 10.5 l
- Noise: 49 dB (A) re 1 pW
- Connected load: 220 – 240 V

#### Features, comfort

- 6 programs: Intensive, Heavy, Eco, Glass, 90 min., Rapid
- Type of control: Electronic Control
- Type of display: light
- Power of heat element (230 V): 1,800 W
- Timer pre-setting 3h / 6h / 9h
- Push button functions: On / Off Button, Program Button, Delay Button, Half load, start / pause
- Functions of Indicator: Rinse Aid, end of the program, Delay time, Half load functions, program, on / off
- Type of heating element: Hidden
- Filter type: Main filter / Coarse filter / Fine filter
- Filter material: Plastic + stainless steel
- Tub material: Stainless steel
- Aquastop
- Cutlery basket in lower basket

#### Dimensions H × W × D

- Appliance dimensions: 81.5 × 59.8 × 57.0 cm
- Recess dimensions: 81.5 × 59.8 × 57.0 cm

<sup>1)</sup> Consumption per year for 280 standard cleaning cycles with cold water filling (for energy consumption: incl. consumption by operating modes with low power consumption).

<sup>2)</sup> Consumption per dishwashing cycle with cold water filling (for energy consumption: including consumption by operating modes with low power consumption). Actual consumption with energy / water consumption depending on the type of use of the machine.



## Built-in dishwasher, fully integrated

### 5VF 420AU



#### Output, consumption

- Energy efficiency class: 3 star
- Water consumption class: 4.5 star
- Capacity: 12 standard place settings
- Energy / water<sup>1)</sup>: 199 kWh / 2,940 l
- Energy / water<sup>2)</sup>: 0.71 kWh / 10.5 l
- Noise: 49 dB (A) re 1 pW
- Voltage: 220 – 240 V

#### Features, comfort

- 7 programs: Intensive, Eco, Heavy, Glass, 90 min., Rapid, Soak
- Type of control: Electronic Control
- Type of display: LED
- Power of heat element (230 V): 1,800 W
- Timer pre-setting 00 – 24 h
- Push button functions: On / Off Button, Program Button, Delay Button, Half load
- Functions of Indicator: Rinse Aid, end of the program, Delay time, Half load functions, program
- Type of heating element: Hidden
- Filter type: Main filter / Coarse filter / Fine filter
- Filter material: Plastic + stainless steel
- Tub material: Stainless steel
- Aquastop
- Cutlery basket in lower basket

#### Dimensions H × W × D

- Appliance dimensions: 81.5 × 59.8 × 55.0 cm
- Built-in dimensions: 81.5 × 59.8 × 55.0 cm



## Free-standing dishwasher

### 5VS 400AU

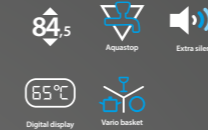

#### Output, consumption

- Energy efficiency class: 3.5 star
- Water consumption class: 4.5 star
- Capacity: 14 standard place settings
- Energy / water<sup>1)</sup>: 205 kWh / 3,556 l
- Energy / water<sup>2)</sup>: 0.73 kWh / 12.7 l
- Noise: 47 dB (A)
- Connected load: 220 – 240 V

#### Features, comfort

- 6 programs: Intensive, Heavy, Eco, Glass, 1 hour, Rapid
- Type of display: LED
- Power of heat element (230 V): 1,800 W
- Timer pre-setting 24 h
- Push button functions: On / Off Button, Program Button, Delay Button, Half load, start / pause
- Functions of Indicator: Rinse Aid, end of the program, Delay time, Half load functions, program, on / off
- Type of heating element: Hidden
- Filter type: Main filter / Coarse filter / Fine filter
- Filter material: Plastic + stainless steel
- Tub material: Stainless steel
- Aquastop
- Cutlery drawer

#### Dimensions H × W × D

- Appliance dimensions: 84.5 × 60.0 × 59.8 cm





# BLAUPUNKT ADDITIONAL ACCESSORIES

Adapt your use and increase the functionality of your appliance  
with our selection of additional accessories.



Visit us and  
find out more ...





## Special accessories for ovens

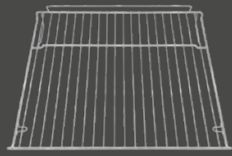

**Multi-use wire shelf**

5Z 10CR10X0

**Compatible with**

5B10N 0240AU  
5B20N 0290AU



**Universal pan**

5Z 36BA50

**Compatible with**

5B36N 0250AU 5B10N 0240AU  
5B36P 0250AU 5B20N 0290AU

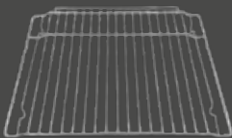

**Multi-use wire shelf**

5Z 36CR10X0

**Compatible with**

5B36N 0250AU  
5B36P 0250AU



**Enamelled baking tray**

5Z 50CB10E0

**Compatible with**

5B50P 8590GB  
5C90S 8990GB  
5B50N 8590GB

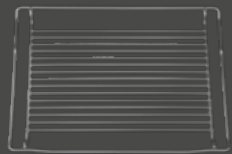

**Multi-use wire shelf**

5Z 50CR10X0

**Compatible with**

5B50P 8590GB  
5C90S 8990GB  
5B50N 8590GB



**Universal pan**

5Z 94CB10E0

**Compatible with**

5BC 93190AU  
5BC 94190AU

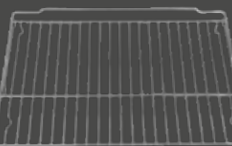

**Multi-use wire shelf**

5Z 94CR10X0

**Compatible with**

5BC 93190AU  
5BC 94190AU



**Universal pan**

5Z 91CB10E0

**Compatible with**

5RC 91490AU

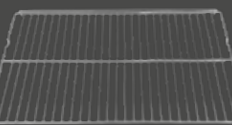

**Multi-use wire shelf**

5Z 91CR10X0

**Compatible with**

5RC 91490AU



**Telescopic extension rail**

5Z 50CU10E0

**Compatible with**

5B50P 8590GB  
5B50N 8590GB

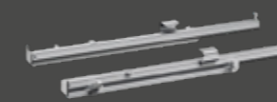

**Telescopic extension rail**

5Z 36VC50

**Compatible with**

5B36N 0250AU  
5B36P 0250AU

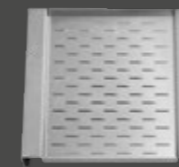

**Steamer insert (stainless steel)**

5Z 94LB50

**Compatible with**

5KD 94150GB



**Steamer insert (stainless steel)**

5Z 50CS10E0

**Compatible with**

5C90S 8990GB

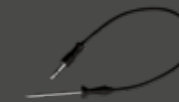

**Temperature probe**

5Z 50TE10E1

**Compatible with**

5C90S 8990GB

## Special accessories for hobs



**Griddle**

5Z 99GP01

EG 13941

**Compatible with**

all Blaupunkt hobs

cast iron

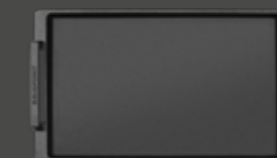

**Teppan Yaki plate**

5Z 99TP01

EG 13942

**Compatible with**



all Blaupunkt hobs

cast iron

## Accessories for hobs with integrated extraction

	<b>Wall box with stainless steel external vent</b> FK 130 plastic	<b>Compatible with</b> 5IX 99290AU	plastic
	<b>Base ventilation grille</b> FK 150 plastic	<b>Compatible with</b> 5IX 99290AU	plastic
	<b>Connector 15° curve - horizontal -</b> FK 113 plastic	<b>Compatible with</b> 5IX 99290AU	plastic
	<b>Coupling</b> FK 110 plastic	<b>Compatible with</b> 5IX 99290AU	plastic
	<b>Connector 90° elbow - horizontal -</b> FK 111 plastic	<b>Compatible with</b> 5IX 99290AU	plastic
	<b>Connector 90° elbow - vertical -</b> FK 112 plastic	<b>Compatible with</b> 5IX 99290AU	plastic
	<b>Flat duct</b> FK 100 plastic	<b>Compatible with</b> 5IX 99290AU	plastic
	<b>Kit for right air outlet</b> 5Z 9104X1 EG 13991	<b>Compatible with</b> 5IX 99290AU	
	<b>Activated carbon filter</b> 5Z 9105X1 EG 13992	<b>Compatible with</b> 5IX 99290AU	
	<b>Set of 2 activated carbon filters</b> 5Z 9009LF1 EG 13961	<b>Compatible with</b> 5IX 99290AU	

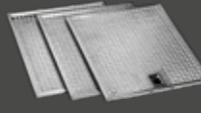
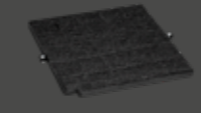
## Special accessories for extractor fan hoods

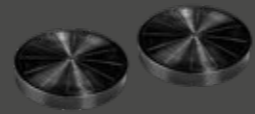
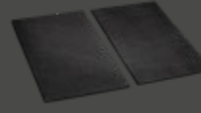
	<b>Stainless steel metallic grease filter</b> 5Z 9203X1 EG 18541	<b>Compatible with</b> 5DB 69253AU
	<b>Activated carbon filter</b> 5Z 9102X1	<b>Compatible with</b> 5DB 69253AU
	<b>Metal handle</b> 5Z 5750N0	<b>Compatible with</b> 5DA 36258AU
	<b>Activated carbon filter</b> 5Z 9121X1	<b>Compatible with</b> 5DA 36258AU 5DA 39258AU 5DA 15250AU 5DA 17250AU 5DA 15151AU 5DA 17151AU
	<b>Activated carbon filter</b> 5Z 9100X1	<b>Compatible with</b> 5DW 66750AU 5DW 69750AU 5DA 45450AU 5DA 49450AU
	<b>Long-life activated carbon filter</b> 5Z 9135X1	<b>Compatible with</b> 5DD 72555AU



# Technical Drawings



# Ovens

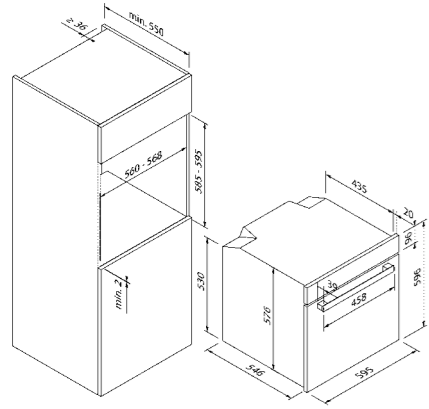

**Suitable for oven TU**  
5B50P 8590GB    5B50N 8590GB

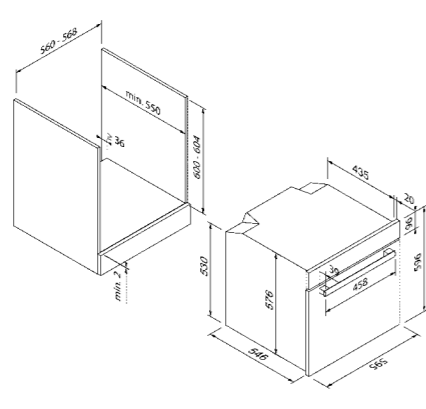

**Suitable for oven BU**  
5B50P 8590GB    5B50N 8590GB

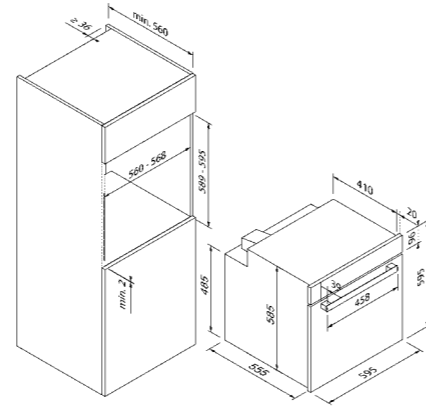

**Suitable for oven TU**  
5B36P 0250AU    5B36N 0250AU

# Compact appliances

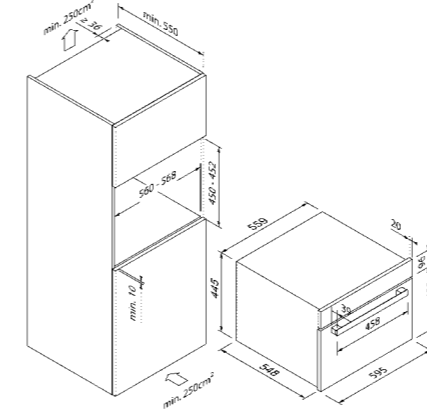

**Suitable for compact appliance**  
5KD 94150GB

# Microwaves

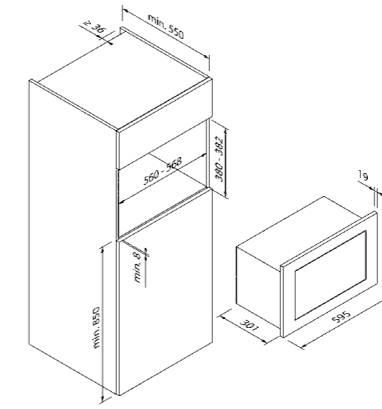

**Suitable for microwave TU**  
5MA 27500AU    5MG 17190AU

# Warming drawer

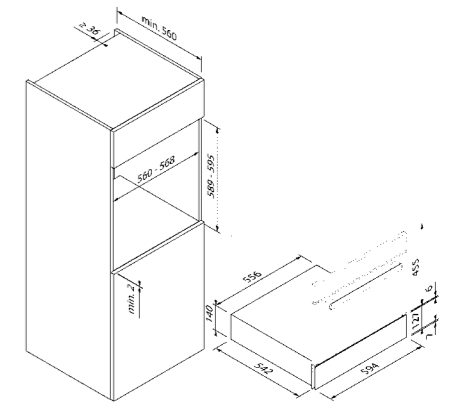

**Suitable for warming drawer**  
5WS 16400    5WS 16401

# Hobs

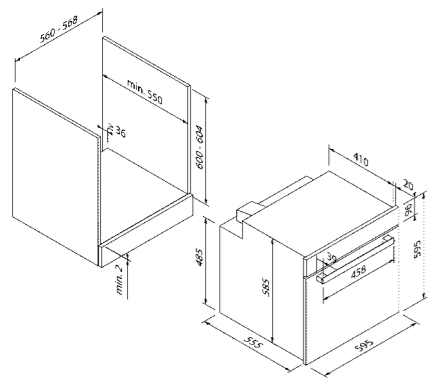

**Suitable for oven BU**  
5B36P 0250AU    5B36N 0250AU

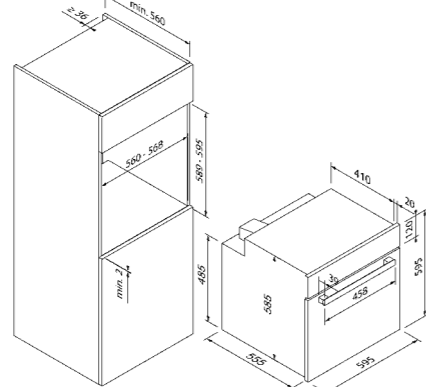

**Suitable for oven TU**  
5B20N 0290AU    5B10N 0240AU

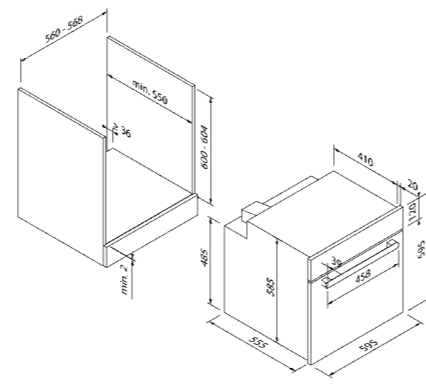

**Suitable for oven BU**  
5B20N 0290AU    5B10N 0240AU

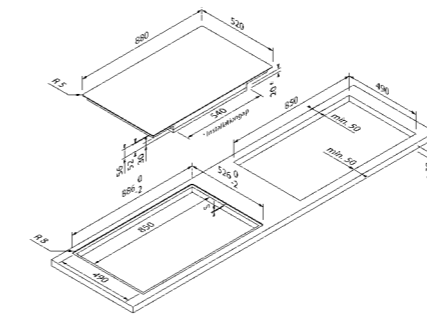

**Suitable for hob | induction, stand-alone**  
5I1 94291

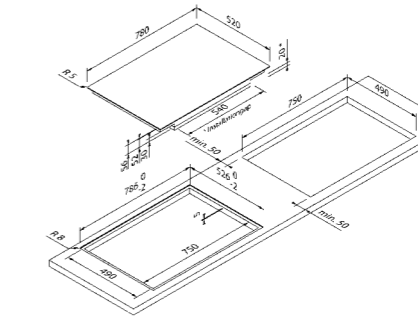

**Suitable for hob | induction, stand-alone**  
5I1E 84252

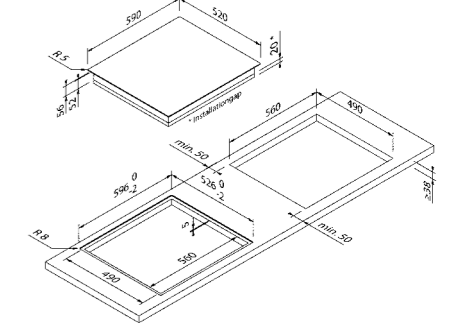

**Suitable for hob | induction, stand-alone**  
5I1E 64252

# Range Cooker

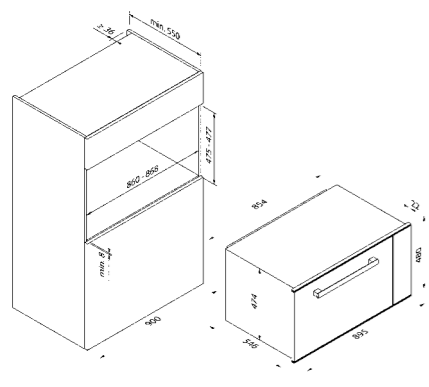

**Suitable for oven TU**  
5BC 94190AU    5BC 93190AU

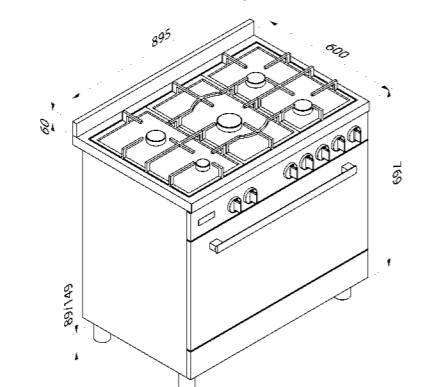

**Suitable for range cooker | free-standing**  
5RC 91490AU

# Compact appliances

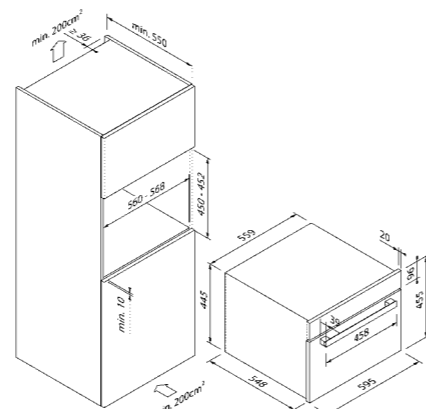

**Suitable for compact appliance**  
5C90S 8990GB

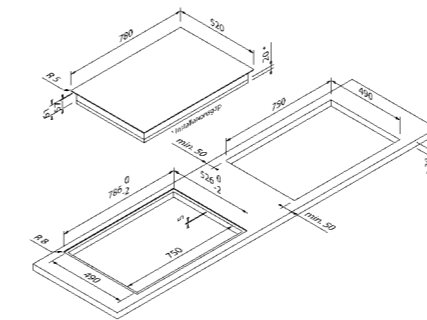

**Suitable for hob | stand-alone**  
5RG 74351

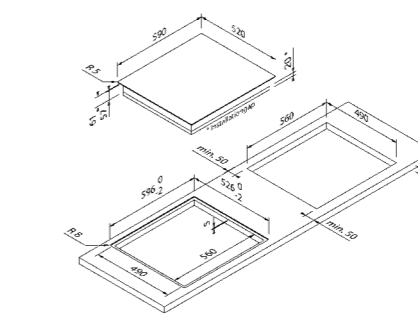

**Suitable for hob | stand-alone**  
5RG 64361    5RE 64361

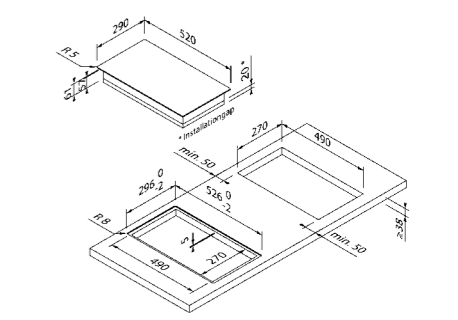

**Suitable for hob | stand-alone**  
5RZ 34411



## Gas hobs

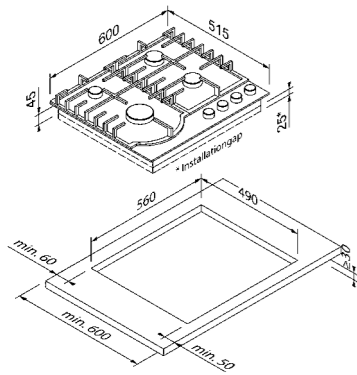

Suitable for gas hob

5GB 62191AU

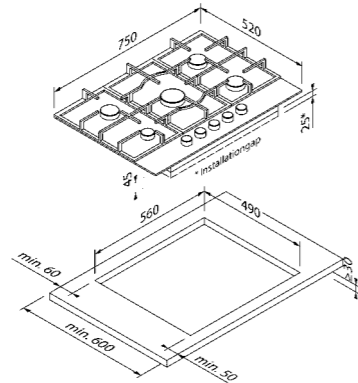

Suitable for gas hob

5GB 72290AU

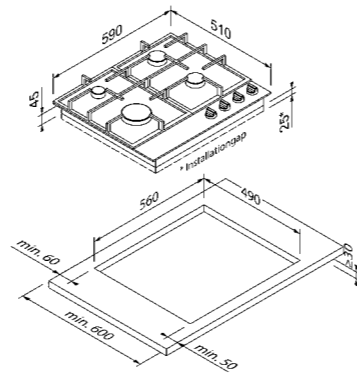

Suitable for gas hob

5GB 61151AU

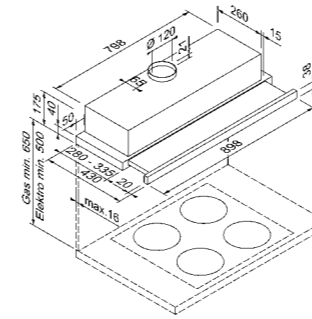

Suitable for flat hood

5DA 39258AU

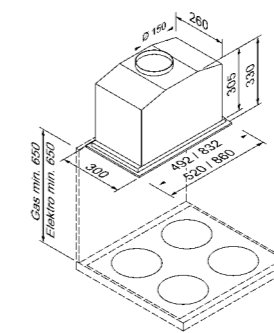

Suitable for fan module

5DA 45450AU 5DA 49450AU

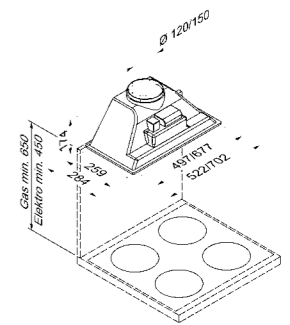

Suitable for fan module

5DA 15250AU 5DA 15151AU  
5DA 17250AU 5DA 17151AU

## Downdraft

## Ceiling fans

## Dishwashers

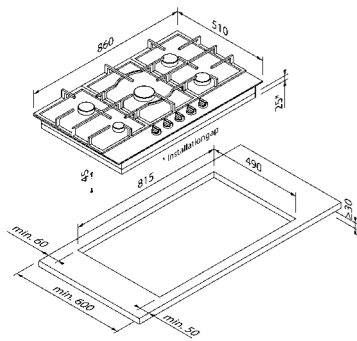

Suitable for gas hob

5GB 91250AU

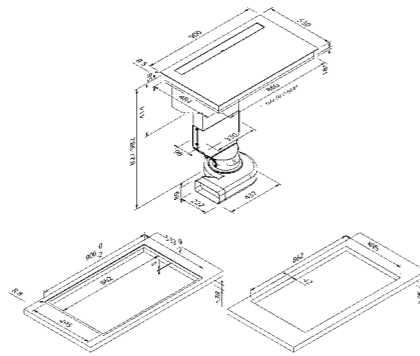

Stand-alone hob, integrated extractor fan

5IX 99290AU

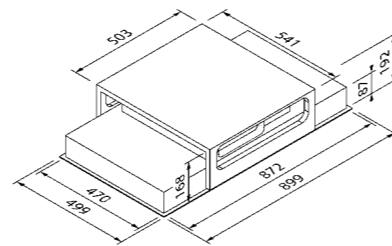

Suitable for ceiling fan

5DD 72555AU

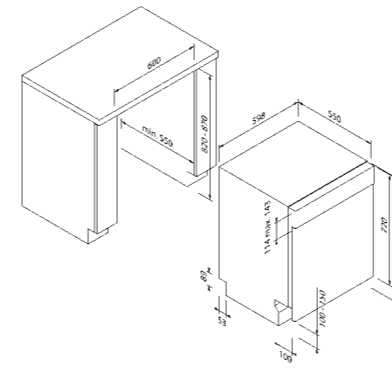

Suitable for dishwasher | fully integrated

5VI 310AU

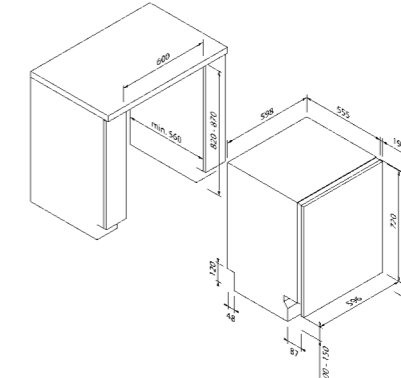

Suitable for dishwasher | fully integrated

5VF 420AU

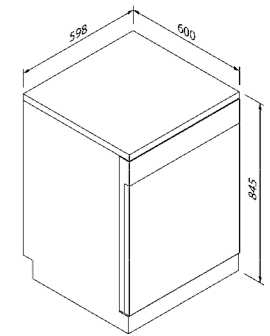

Suitable for dishwasher | free-standing

5VS 400AU

## Wall flues

## Flat Hood

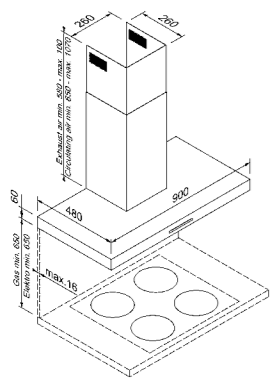

Suitable for wall flue

5DB 69253AU

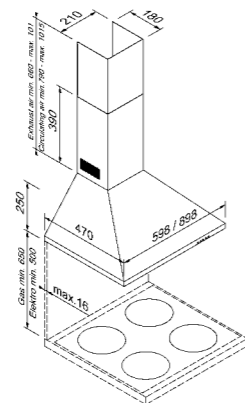

Suitable for wall flue

5DW 66750AU 5DW 69750AU

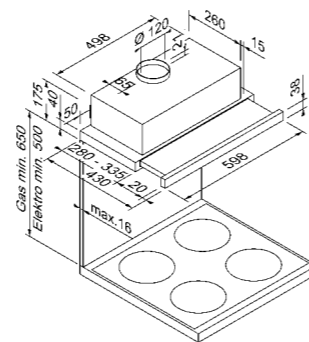

Suitable for flat hood

5DA 36258AU

## Service



By opting for Blaupunkt appliances, you have chosen a piece of premium kitchen equipment. Our professional service is available to assist you after the purchase. Our qualified employees are pleased to remain at your disposal. Our customer service experts for Blaupunkt integrated kitchen appliances will professionally answer all questions about the appliances. Here you can obtain all information on handling, functions and performance.

[www.blaupunkt.com](http://www.blaupunkt.com)  
[www.blaupunkt-einbaugeraete.com](http://www.blaupunkt-einbaugeraete.com)

**Blaupunkt integrated kitchen appliances /  
customer service, repair service, user  
support, spare parts and accessories.**

**Tel.: 1800 252 878 658  
1800 BLAUPUNKT**

**[customercare@blaupunkt.com](mailto:customercare@blaupunkt.com)**



Register your new device on:  
[blaupunkt.com](http://blaupunkt.com)

Nikpol Pty Ltd

[www.nikpol.com.au](http://www.nikpol.com.au)  
1300 645 765  
[sales@nikpol.com.au](mailto:sales@nikpol.com.au)

VIC  
6 – 12 Fairchild Street  
Heatherton VIC 3202

QLD  
19 William Farrior Place  
Eagle Farm QLD 4009

NSW  
2 / 5 Bessemer Street  
Blacktown NSW 2148

